

**International  
Progress Report**

**IPR-10-15**

**Äspö Hard Rock Laboratory**

**Status Report**

**January - April 2010**

Svensk Kärnbränslehantering AB

October 2010

**Svensk Kärnbränslehantering AB**

Swedish Nuclear Fuel  
and Waste Management Co

Box 250, SE-101 24 Stockholm  
Phone +46 8 459 84 00



**Äspö Hard Rock  
Laboratory**

Report no.  
IPR-10-15

Author  
Kemakta

Checked by

Approved  
Mats Ohlsson

No.  
F50K

Date  
October 2010

Date

Date  
2010-10-11

# **Äspö Hard Rock Laboratory**

## **Status Report**

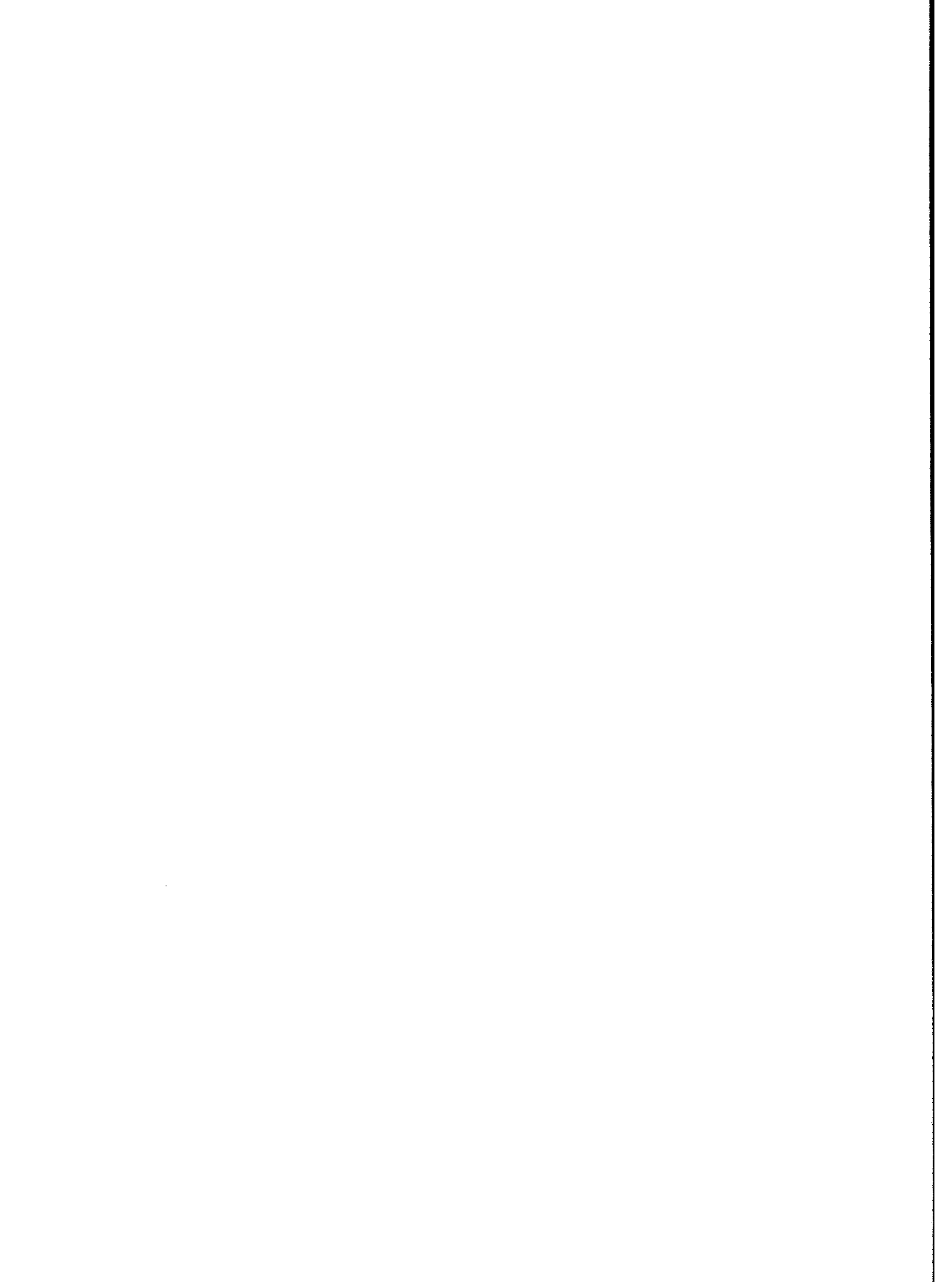
### **January – April 2010**

Svensk Kärnbränslehantering AB

October 2010

*Keywords:* Äspö HRL, Status Report

This report concerns a study which was conducted for SKB. The conclusions and viewpoints presented in the report are those of the author(s) and do not necessarily coincide with those of the client.



# Overview

The Äspö Hard Rock Laboratory (HRL) constitutes an important part of SKB's work to design and construct a geological repository for spent nuclear fuel and to develop and test methods for characterisation of a suitable site. The plans for SKB's research and development of technique during the period 2008–2013 are presented in SKB's RD&D-Programme 2007 /SKB 2007/. The information given in the RD&D-Programme related to Äspö HRL is annually detailed in the Äspö HRL Planning Report /SKB 2009/.

This Äspö HRL Status Report is a collection of the main achievements obtained during the period January to April 2010.

## **Geoscience**

Geoscientific research is a natural part of the activities at Äspö HRL and is conducted in the fields of Geology, Hydrogeology, Geochemistry and Rock Mechanics. The major aims are to establish and maintain geoscientific models of the Äspö HRL rock mass and to establish and develop the understanding of the Äspö HRL rock mass properties as well as the knowledge of applicable measurement methods.

## **Natural barriers**

Many experiments in Äspö HRL are related to the rock, its properties and in situ environmental conditions. The goals are to increase the scientific knowledge of the safety margins of a final repository and to provide data for performance and safety assessment. The ongoing projects and experiments are: Tracer Retention Understanding Experiments, Long Term Sorption Diffusion Experiment, Colloid Transport Project, Microbe Projects, Matrix Fluid Chemistry Continuation, Radionuclide Retention Experiments, Padamot, Fe-oxides in Fractures, Investigation of Sulphide Production Processes in Groundwater, Swiw-tests with Synthetic Groundwater and Äspö Model for Radionuclide Sorption. Tests of models for groundwater flow, radionuclide migration and chemical/biological processes are addressed in the Task Force on Modelling of Groundwater Flow and Transport of Solutes.

## **Engineered barriers**

Another goal for Äspö HRL is to demonstrate technology for and function of important parts of the repository system. This implies translation of current scientific knowledge and state-of-the-art technology into engineering practice applicable in a real repository. The ongoing projects and experiments are: Prototype Repository, Long Term Test of Buffer Material, Alternative Buffer Materials, Backfill and Plug Test, Canister Retrieval Test, Temperature Buffer Test, KBS-3 Method with Horizontal Emplacement, Large Scale Gas Injection Test, Sealing of Tunnel at Great Depth, In Situ Corrosion Testing of Miniature Canisters, Cleaning and Sealing of Investigation Boreholes, Concrete and Clay, Low-pH Programme, Drilling Machine for Deposition Holes and Development of End Plugs for Deposition Tunnels. THM processes and gas migration in buffer material are addressed in the Task Force on Engineered Barrier Systems and in a parallel Task Force geochemical processes in engineered barriers are studied.

### ***Mechanical- and system engineering***

At Äspö HRL and the Canister Laboratory in Oskarshamn, technologies for the final disposal of spent nuclear fuel are being developed. Established as well as new technology will be used in the final repository. When it comes to mechanical- and system engineering, well known standard objects with secured function will be used to the fullest possible extent. With standard equipment as a basis needed adjustments, modifications and adaptations can be made for the intended function. Where no standard objects are available, new technical development will be necessary. Projects are on-going concerning equipment for backfilling, buffer emplacement, ramp vehicle, deposition machine, logistics study, multi purpose vehicle, transport system, drill and production system.

### ***Äspö facility***

The Äspö facility consists of the Hard Rock Laboratory and the Bentonite Laboratory which were taken into operation in 1995 and 2007 respectively. Important parts of the activities at the Äspö facility are the administration, operation and maintenance of instruments as well as the development of investigation methods. The Public Relations and Visitor Services group is responsible for presenting information about SKB and its facilities. They arrange visits to the facilities all year around as well as special events.

### ***Environmental research***

Äspö Environmental Research Foundation was founded 1996 on the initiative of local and regional interested parties. The aim was to make the underground laboratory at Äspö and its resources available for national and international environmental research. During 2003-2008 the activities were concentrated to the Äspö Research School. According to plan the activities in the school were concluded in 2008 and the remaining and new research activities were transferred within the frame of a new co-operation, Nova Research and Development (Nova FoU).

### ***International co-operation***

The Äspö HRL has during the years attracted considerable international interest. Nine organisations from eight countries participate in the co-operation or in Äspö HRL related activities, apart from SKB, during 2010.

# Contents

<b>1</b>	<b>General</b>	<b>7</b>
<b>2</b>	<b>Geoscience</b>	<b>9</b>
2.1	General	9
2.2	Äspö Site Descriptive Model	10
2.3	Geology	10
2.3.1	Geological Mapping and Modelling	11
2.3.2	RoCS – Method Development of a New Technique for Underground Surveying	12
2.4	Hydrogeology	12
2.4.1	Hydro Monitoring Programme	13
2.5	Geochemistry	14
2.5.1	Monitoring of Groundwater Chemistry	15
2.6	Rock Mechanics	15
2.6.1	Counterforce Applied to Prevent Spalling	16
<b>3</b>	<b>Natural barriers</b>	<b>17</b>
3.1	General	17
3.2	Tracer Retention Understanding Experiments	18
3.2.1	TRUE Block Scale Continuation	19
3.2.2	TRUE-1 Continuation	19
3.2.3	TRUE-1 Completion	20
3.3	Long Term Sorption Diffusion Experiment	21
3.4	Colloid Transport Project	23
3.5	Microbe Projects	24
3.5.1	Micored	26
3.5.2	Micomig	27
3.6	Matrix Fluid Chemistry Continuation	29
3.7	Radionuclide Retention Experiments	30
3.7.1	Spent Fuel Leaching	30
3.7.2	Transport Resistance at the Buffer-Rock Interface	31
3.8	Padamot	32
3.9	Fe-oxides in Fractures	33
3.10	Investigation of Sulphide Production Processes in Groundwater	34
3.11	Swiw-tests with Synthetic Groundwater	37
3.12	Äspö Model for Radionuclide Sorption	38
3.13	Task Force on Modelling of Groundwater Flow and Transport of Solutes	40
<b>4</b>	<b>Engineered barriers</b>	<b>43</b>
4.1	General	43
4.2	Prototype Repository	44
4.3	Long Term Test of Buffer Material	45
4.4	Alternative Buffer Materials	47
4.5	Backfill and Plug Test	49
4.6	Canister Retrieval Test	50
4.7	Temperature Buffer Test	51
4.8	KBS-3 Method with Horizontal Emplacement	52

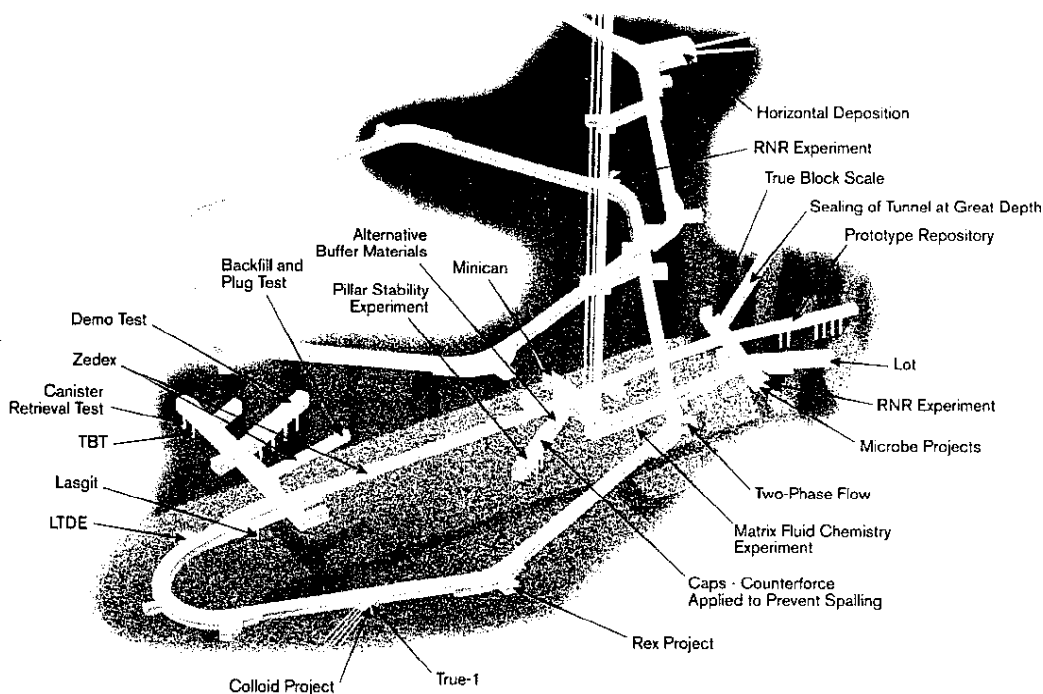
4.9	Large Scale Gas Injection Test	54
4.10	Sealing of Tunnel at Great Depth	56
4.11	In Situ Corrosion Testing of Miniature Canisters	57
4.12	Cleaning and Sealing of Investigation Boreholes	58
4.13	Concrete and Clay	60
4.14	Low-pH Programme	61
4.15	Drilling Machine for Deposition Holes	62
4.16	Development of End Plugs for Deposition Tunnels	63
4.17	Task Force on Engineered Barrier Systems	65
<b>5</b>	<b>Mechanical- and system engineering</b>	<b>67</b>
5.1	General	67
5.2	Technical development at Äspö HRL	67
<b>6</b>	<b>Äspö facility</b>	<b>71</b>
6.1	General	71
6.2	Bentonite Laboratory	72
6.2.1	Impact of Water Inflow on Backfill	73
6.3	Facility Operation	74
6.4	Public Relations and Visitor Services	75
<b>7</b>	<b>Environmental research</b>	<b>77</b>
7.1	General	77
7.2	Nova Research and Development (Nova FoU)	77
7.2.1	Linné Geochemistry Group	81
<b>8</b>	<b>International co-operation</b>	<b>83</b>
8.1	General	83
<b>9</b>	<b>Documentation</b>	<b>85</b>
9.1	Äspö International Progress Reports	85
9.2	Technical Documents and International Technical Documents	85
<b>10</b>	<b>References</b>	<b>87</b>

# 1 General

The Äspö Hard Rock Laboratory (HRL), located in the Simpevarp area in the municipality of Oskarshamn, constitutes an important part of SKB's work with design and construction of a deep geological repository for final disposal of spent nuclear fuel. One of the fundamental reasons behind SKB's decision to construct an underground laboratory was to create an opportunity for research, development and demonstration in a realistic and undisturbed rock environment down to repository depth. In the Bentonite Laboratory, taken into operation in 2007, studies on buffer and backfill materials are performed to complement the studies performed in Äspö HRL.

The underground part of the laboratory consists of a tunnel from the Simpevarp peninsula to the southern part of Äspö where the tunnel continues in a spiral down to a depth of 460 m. The rock volume and the available underground excavations are divided between numerous experiments performed at the Äspö HRL. In Figure 1-1, the allocation of the main experimental sites in Äspö HRL is shown.

SKB's overall plans for research, development and demonstration during the period 2008–2013 are presented in SKB's RD&D-Programme 2007 /SKB 2007/. The planned activities related to Äspö HRL are detailed on a yearly basis in the Äspö HRL Planning Report /SKB 2009/. This Status Report presents main achievements during the period January to April 2010. In the Annual Report more detailed information is given of new findings and results obtained during the whole year.



*Figure 1-1 Overview of the Äspö HRL and the allocation of the experimental sites from -220 m to -450 m level.*



## 2 Geoscience

### 2.1 General

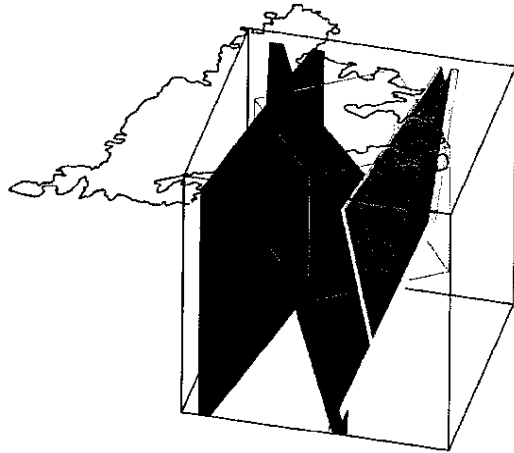
Geoscientific research is a part of the activities at Äspö HRL and is conducted in the fields of geology, hydrogeology, geochemistry and rock mechanics. The studies include laboratory and field experiments, as well as modelling work. The objectives are to:

- Establish and develop geoscientific models of the Äspö HRL rock mass and its properties.
- Establish and develop the knowledge of applicable measurement methods.

The main task within the geoscientific field is the development of an Äspö Site Descriptive Model (SDM) integrating the information from the fields of geology, hydrogeology, geochemistry and rock mechanics, see section 2.2. The SDM will facilitate the understanding of the geological, hydrogeological, geochemical and rock mechanical conditions at the site and the evolution of the conditions during operation of Äspö HRL.

The activities further aim to provide basic geoscientific data to the experiments and to ensure high quality of experiments and measurements related to geosciences.

## 2.2 Äspö Site Descriptive Model



The development of an Äspö Site Descriptive Model (SDM) will facilitate the understanding of the geological, hydrogeological and geochemical conditions at the site and the evolution of the conditions during operation of the facility.

The SDM also provides basic geoscientific data to support predictions and planning of experiments performed in Äspö HRL.

The aim is also to ensure high quality of experiments and measurements related to geosciences.

### ***Achievements***

During the first four month of 2010, the work with the Äspö SDM (Site Descriptive Model) continues. Single-hole interpretations are now on-going and about 15 boreholes have been interpreted.

Hydrogeological single-hole interpretation was introduced to be undertaken together with the geological single-hole interpretation with the objective to arrive at an integrated hydrogeological interpretation. This entails establishing a methodology and then the execution of it for a limited number of boreholes. This activity was initiated and is ongoing.

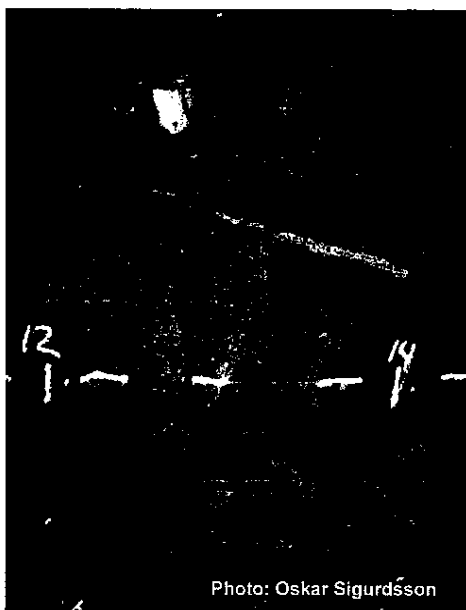
Digital borehole images (BIPS) were taken of borehole KC0045F in order to support the single-hole interpretation and the further modelling of hydrogeological structures. Images proved to be of low to moderate quality but hopefully still useful for the orientation of the core.

An in-situ pH measurement has been performed in the tunnel in several boreholes to assist the hydrogeochemical modelling for Äspö SDM.

## 2.3 Geology

Geological work at Äspö HRL is covering several fields. Major responsibilities are mapping of tunnels, deposition holes and drill cores, as well as continuous updating of the geological three-dimensional model of the Äspö rock volume. In addition, the development of new methods in the field of geology is a major responsibility.

### 2.3.1 Geological Mapping and Modelling



*The TASS-tunnel, left wall, section 12-14 m. In the lower part a sub-horizontal, epidote healed fracture displacing a pegmatite dyke and in the middle a quartz lens cross-cutting the same dyke.*

All rock surfaces and drill cores at Äspö are mapped. This is done in order to increase the understanding of geometries and properties of rock types and structures, which is subsequently used as input in the 3D-modelling of the rock volume together with other input data.

#### **Achievements**

The main activities or achievements during January to April 2010 have been:

- The report concerning the geology of the Tass-tunnel is completed and will be sent for review.
- The report concerning water bearing structures at the -450 m level has been adjusted and now sent for a second review.
- The orientations of fractures and deformation zones in the Äspö HRL are being plotted in stereo and rose diagrams. The plots show fractures plus deformation zones, only fractures or deformation zones, only water bearing or dry fractures/zones. The diagrams represent the total tunnel system or the tunnel system divided into sections.
- The drawing summarising the geological mapping of all the Äspö-tunnels is being up-dated to include the mapping of new tunnels and the colours used in the new rock type nomenclature.
- The work regarding copying the TMS (Tunnel Mapping System) database to the Sicada database is on-going.
- Updating of the instruction how to handle and sample drill cores is on-going.

### 2.3.2 RoCS – Method Development of a New Technique for Underground Surveying



*Some equipment - digital camera and a laptop - used for photogrammetry in the TASS-tunnel.*

A feasibility study concerning geological mapping techniques has been completed (Magnor et al. 2007). Based on the knowledge from the feasibility study SKB has commenced a new phase of the RoCS project, here referred to as RoCS-II.

The purpose is to investigate if a new system for rock characterisation has to be adopted when constructing a final repository. The major reasons for the project are aspects on objectivity of the data collected, traceability of the mappings performed, saving of time required for mapping and data treatment and precision in mapping. These aspects all represent areas where the present mapping technique may not be adequate.

The project will concentrate on finding or constructing a new geological underground mapping system. Laser scanning in combination with digital photography and/or photogrammetry will be a part of that system. The resulting mapping system shall operate in a colour 3D environment where the xyz-coordinates are known.

### **Achievements**

The work with the RoCS-project has been resumed. An offer to develop SKB's geological mapping system, based on the principles of the Boremap-core logging system and photogrammetry has been received and is now being evaluated.

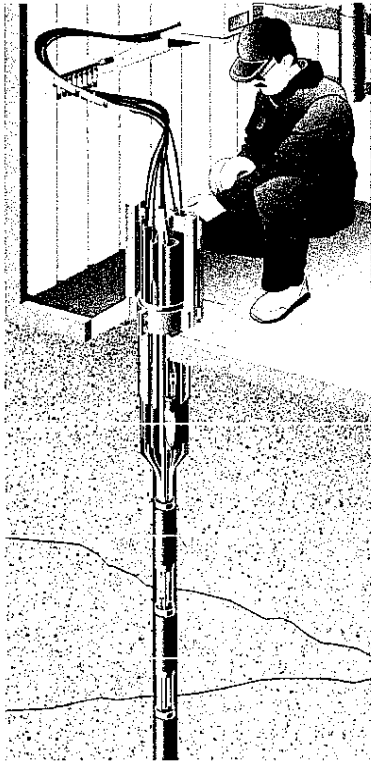
## 2.4 Hydrogeology

The objectives of the hydrogeological work are to:

- Establish and develop applicable methods for measurement, testing and analysis for the understanding of the hydrogeological properties of the Äspö HRL rock mass.
- Ensure that experiments and measurements in the field of hydrogeology are performed with high quality.

The main tasks are firstly to continue work for further development of quality control and quality assurance procedures in the field of hydrogeology and secondly to upgrade the Äspö Site Descriptive Model. The main features are the inclusion of additional data collected from various experiments and the adoption of modelling procedures developed during the site investigations. The intention is to develop the model into a dynamic working tool suitable for predictions in support of the experiments in the laboratory as well as to test hydrogeological hypotheses. Another part of the work with the site description is the continued development of a more detailed model of hydraulic structures at the main experimental sites.

## 2.4.1 Hydro Monitoring Programme



The hydro monitoring programme is an important part of the hydrogeological research and a support to the experiments undertaken in Äspö HRL. The monitoring of water level in surface boreholes started in 1987 while the computerised Hydro Monitoring System (HMS) was introduced in 1992.

The HMS collects data on-line of pressure, levels, flow and electrical conductivity of the groundwater. The data are recorded by numerous transducers installed in boreholes. The number of boreholes included in the monitoring programme has gradually increased, and comprise boreholes in the tunnel in the Äspö HRL as well as surface boreholes on the islands of Äspö, Ävrö, Mjälén, Bockholmen and some boreholes on the mainland at Laxemar. To date the monitoring programme comprises a total of about 140 boreholes (about 40 surface boreholes and 100 tunnel boreholes). Many boreholes are equipped with inflatable packers, dividing the borehole into sections. Water seeping into the tunnel is diverted to trenches and further to 25 weirs where the flow is measured.

Weekly quality checks of preliminary groundwater head data are performed. Absolute calibration of data registered with HMS is performed three to four times annually. This work involves comparison with groundwater levels checked manually in boreholes.

The data collected in HMS is transferred to SKB's site characterisation database, Sicada.

### **Achievements**

The hydrogeological monitoring has continued. Monitoring points were maintained and performing well, particularly the equipment installed in the tunnel. Boreholes KAS03 and KAS09, which were refurbished last year, are now both operational and are now monitoring online hydraulic head.

After the discontinuation of the monitoring system of Site Investigations at Oskarshamn, a limited number of monitoring objects were transferred to Äspö HRL as of January 1<sup>st</sup> 2010. Äspö HRL is charged with the task of demobilising all remaining monitoring installations of the Site Investigations.

The monitoring is reported every four-month period through quality control documents and on an annual basis. In the annual report the measurement system and basic results are given. The annual monitoring report for 2009 is still pending due to delays incurred in the transfer process of the Site Investigation monitoring objects to Äspö.

## 2.5 Geochemistry

The major aims within geochemistry are to:

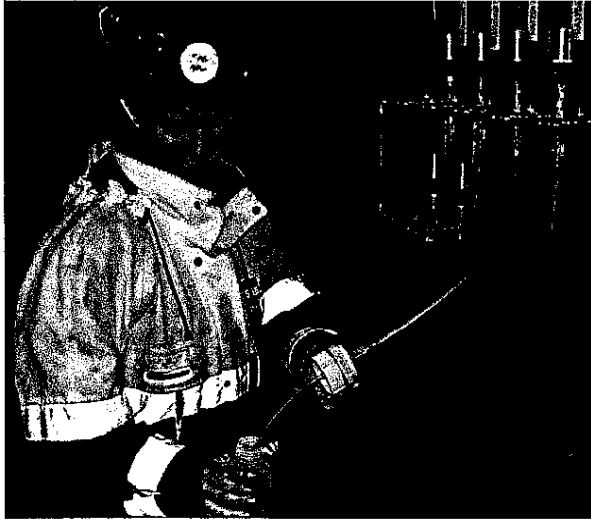
- Establish and develop the understanding of the hydrogeochemical properties of the Äspö HRL rock volume.
- Maintain and develop the knowledge of applicable measuring and analytical methods.
- Ensure that experimental sampling programmes are performed with high quality and meet overall goals within the field area.

There is a need to develop method descriptions for the actual sampling procedures at field (underground, excavation of tunnel) for the hydrogeochemical work. In addition, instructions for procedures for quality assurance of hydro-chemical data to be included in the site characterisation database Sicada need to be established. The main task is to develop quality control and quality assurance procedures in the field of hydrochemistry and geochemistry.

### ***Achievements***

The results from the Sulphide project sampling in KLX03, KLX06 and KAS09 has been evaluated and submitted in a draft report. The planning and selection of new boreholes in the Äspö tunnel for the continuation of the project is completed. The new sampling for chemistry, gases and microbes started in April 2010. The project Microbial Mineralization, run by Göttingen University, has started and reactors have been installed in two boreholes for sampling of biofilm and microbial precipitates. The activity in Micored project no 4 is launched and sampling series for oxygen production and changes in redox potential will be monitored over time at 450 m level in the tunnel.

## 2.5.1 Monitoring of Groundwater Chemistry



*Water sampling in a tunnel at Äspö HRL.*

During the Äspö HRL construction phase, water samples were collected and analysed with the purpose of monitoring the groundwater chemistry and its evolution as the construction proceeded. The samples were obtained from boreholes drilled from the ground surface and from the tunnel. At the beginning of the operational phase, sampling was replaced by a groundwater chemistry monitoring programme, with the aim to sufficiently cover the evolution of hydrochemical conditions with respect to time and space within the Äspö HRL.

The monitoring programme is designed to provide information to determine where, within the rock mass, the hydrogeochemical changes are taking place and at what time stationary conditions are established.

### **Achievements**

All data from the last year groundwater monitoring in the Äspö HRL are reported and quality assured in Sicada. The hydrogeochemical sampling for surface- and groundwater in the Laxemar monitoring program has been initiated. The in-situ pH measurement that has been performed in the tunnel in several boreholes to assist the hydrogeochemical modelling for Äspö SDM has not been made in previous monitoring campaigns but will now be included in the future sampling program. A focused program with stationary on-line monitoring equipment for pH, Eh, conductivity and temperature measurements is being developed in collaboration between Nova FoU and SKB.

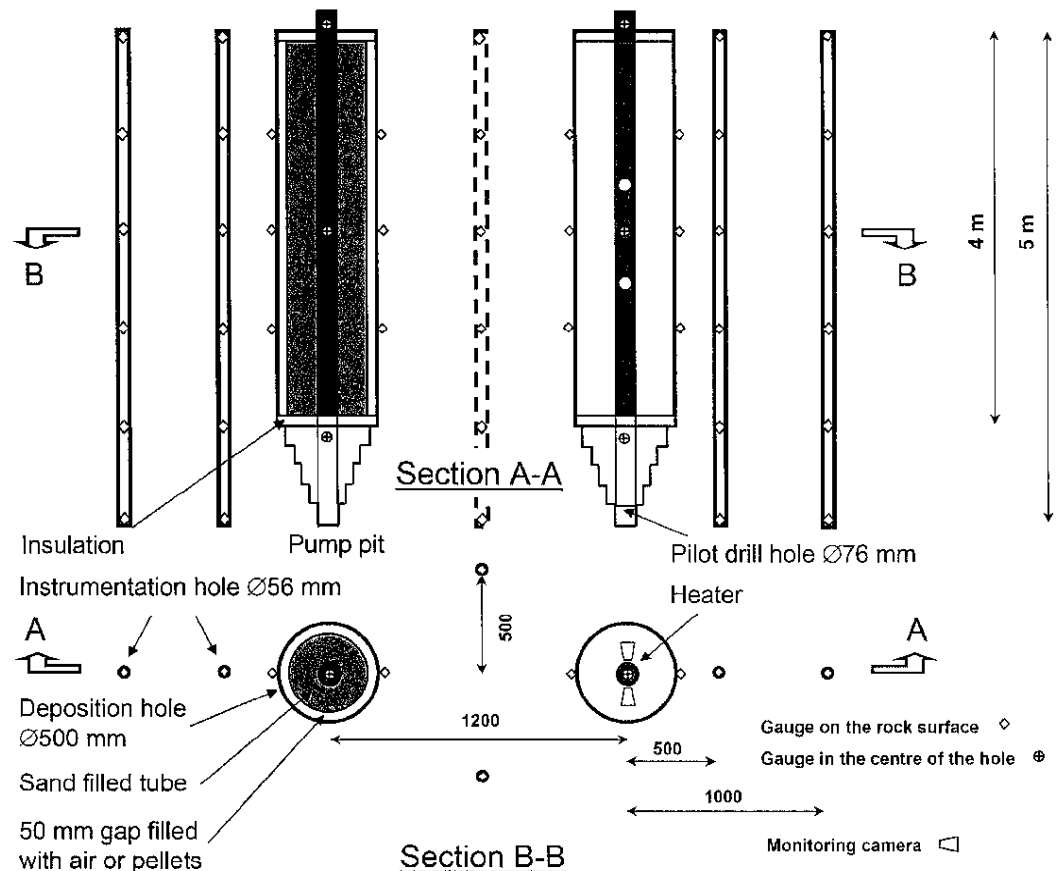
## 2.6 Rock Mechanics

Rock mechanic studies are performed with the aims to increase the understanding of the mechanical properties of the rock but also to recommend methods for measurements and analyses. This is mainly done by laboratory experiments and modelling at different scales and comprises:

- Natural conditions and dynamic processes in natural rock.
- Influences of mechanical, thermal and hydraulic processes in the near-field rock including effects of the backfill.

A project called Caps (Counterforce Applied to Prevent Spalling) comprising field tests in Äspö HRL and numerical modelling is ongoing and is described in the section below.

## 2.6.1 Counterforce Applied to Prevent Spalling



*Configuration of the test holes and the positioning of instruments in the experiments in the Tasq-tunnel as original design with one open and one pellet filled hole. In reality the tests have been performed in two pairs of open holes and two pairs of pellet filled holes.*

The field experiment within Counterforce Applied to Prevent Spalling (Caps) has been initiated as a demonstration experiment to determine if the application of dry bentonite pellets is sufficient to suppress thermally-induced spalling in KBS-3 deposition holes. The experience gained from the Äspö Pillar Stability Experiment, conducted between 2002 and 2006, indicated that spalling could be controlled by the application of a small confining pressure in the deposition holes.

The field experiment includes four pairs of heated half-scale KBS-3 holes and is carried out as a series of demonstration tests in the Tasq-tunnel at Äspö HRL.

Each test consists of two heating holes of 0.5 m diameter and 4 m depth separated by a 0.7 m pillar, which are surrounded by a number of boreholes for installation of temperature gauges.

The first step in the testing sequence includes heating of one pair of open holes to ensure that spalling will occur and can be observed in the test holes. The next step includes heating and observation of spalling in separate pair of holes. A 50 mm gap created between a large inner tube and the borehole wall is filled with a loosely placed pellets substitute. The final step is a complementary test that is carried out to address questions that arise during the previous tests.

### Achievements

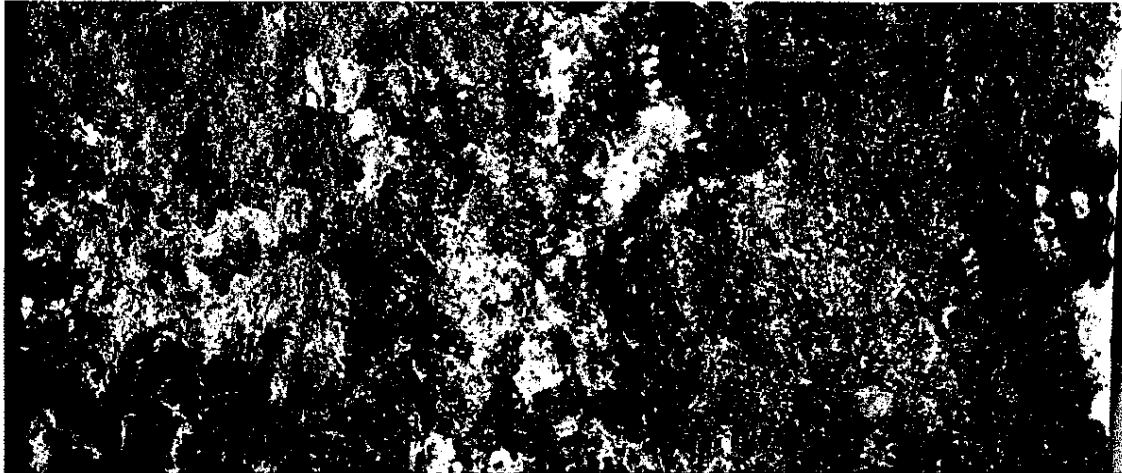
The final report of the field experiment is ready for proofreading and subsequent printing, and the main part of the recorded data has been delivered to Sicada. A paper entitled "Thermal spalling in a field experiment in hard rock" is approved for presentation at the conference "Rock mechanics in the Nordic countries 2010" in Oslo in June.

## 3 Natural barriers

### 3.1 General

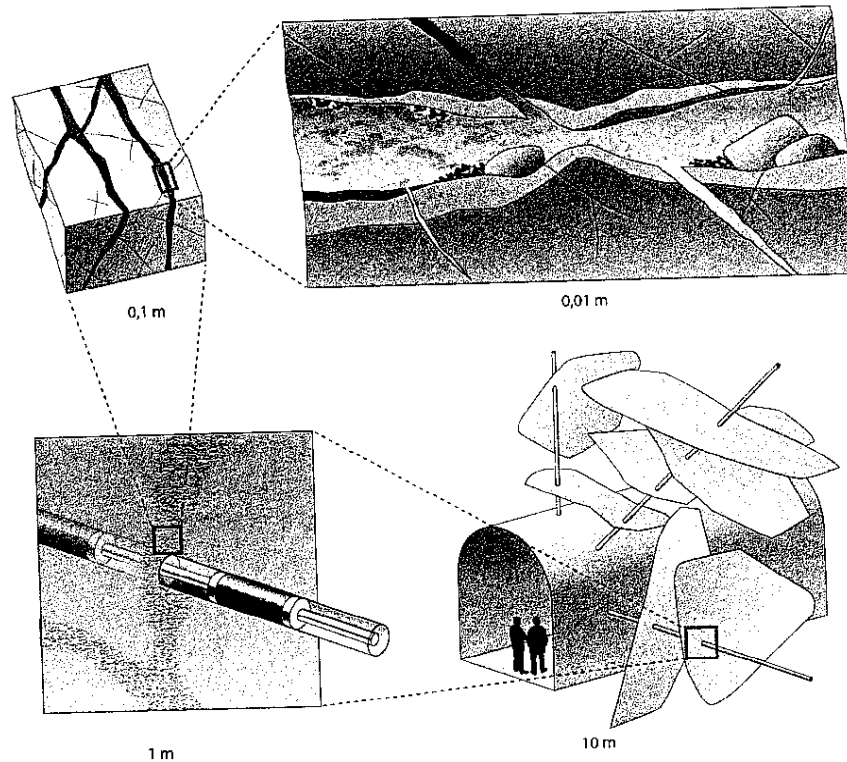
Experiments at the Äspö HRL are performed at conditions that are expected to prevail at repository depth. The experiments are related to the rock, its properties and in situ environmental conditions (Figure 3-1). The goals are to increase the scientific knowledge of the safety margins of the repository and to provide data for performance and safety assessment and thereby clearly present the role of the geosphere for the barrier functions: isolation, retardation and dilution.

Tests of models for groundwater flow, radionuclide migration and chemical/biological processes are one of the main purposes of the Äspö HRL. The programme includes projects with the aim to evaluate the usefulness and reliability of different models and to develop and test methods for determination of parameters required as input to the models.



*Figure 3-1 Fracture surface with thin coating of mainly chlorite, calcite, clay minerals and epidote. The length of the base of the photograph is 46 mm.*

## 3.2 Tracer Retention Understanding Experiments



*Schematic illustration of various scales of heterogeneity addressed by the TRUE experimental programme, ranging from block scale to micro scale. The micro scale illustration (upper right) shows a cross-section of a conductive fracture that includes a zone of enhanced porosity (light brown), fault gouge (dark brown), idiomorphic crystals (yellow) in a hydrothermally altered rim zone (red).*

Tracer tests with non-sorbing and sorbing tracers are carried out in the TRUE family of projects. These are conducted at different scales; laboratory scale (< 0.5 m), detailed scale (<10 m) and block scale (up to 100 m) with the aim to improve understanding of transport and retention in fractured rock.

The work includes building of hydrostructural models and conceptual microstructure models. Numerical models are used to assess the relative contribution of flow-field related effects and acting processes (diffusion and sorption) on in situ retention.

The first in situ experiment (TRUE-1) /Winberg et al. 2000/ performed in the detailed scale and the TRUE Block Scale series of experiments /Winberg et al. 2003/ have come to their respective conclusion. Complementary field work and modelling have been performed as part of two separate, but closely coordinated, continuation projects.

The TRUE Block Scale Continuation (BS2) project, which was a continuation of TRUE Block Scale (BS1), aimed at obtaining additional understanding of the TRUE Block Scale site /Andersson et al. 2007/.

A further extension of the TRUE Block Scale Continuation (BS3) involves production of peer reviewed scientific papers accounting for the overall TRUE findings, and in particular those of BS1 and BS2.

In the TRUE-1 Continuation and Completion projects the objectives are to obtain insight in the internal structure of the investigated feature and to study fixation of sorbing radioactive tracers. Prior to the resin injection in Feature A, complementary hydraulic and tracer tests are performed to better understand Feature A and its relation to the surrounding fracture network. In addition, a dress rehearsal of in situ resin injection is realised through a characterisation project focused on fault rock zones.

Additional work includes complementary laboratory sorption investigations on fracture rim and fault gouge materials, plus a series of three scientific articles on the TRUE-1 experiment.

### **3.2.1 TRUE Block Scale Continuation**

In the aftermath to the BS2 project, a second step of the continuation of the TRUE Block Scale (BS3) was set up. This step has no specific experimental components and emphasise consolidation and integrated evaluation of all relevant TRUE data and findings collected thus far. This integration is not necessarily restricted to TRUE Block Scale, but may include incorporation of relevant TRUE-1 and TRUE-1 Continuation results.

The planned series of articles covering the TRUE Block Scale experiments have been transformed into one two-part article entitled *Transport and retention from single to multiple fractures in crystalline rock at Äspö (Sweden)*:

- I. *Evaluation of tracer test results and sensitivity analysis*
- II. *Fracture network flow simulations and generic retention model*

In addition, there is a stand-alone paper entitled *Significance of fracture rim zone heterogeneity for tracer transport in crystalline rock*.

A second step in the scientific reporting of the TRUE experiments is the production of a more high-profile paper directed to the general scientific public. The tentative title of this paper, aimed at the journal *Science* is "*Would crystalline rock effectively contain radionuclides released from a high-level nuclear waste repository?*" A second paper, submitted to *Geophysical Research Letters*, is entitled *Diffusion-controlled tracer retention in crystalline rock on a field scale*.

#### **Achievements**

The two TRUE Block Scale articles and the article focused on effects of microstructure have been published/printed in *Water Resources Research* /Cvetkovic 2010, Cvetkovic and Frampton 2010, Cvetkovic et al. 2010/. The paper directed to *Geophysical Research Letters* including a more comprehensive supplement has been accepted for publication. Internal review of the paper directed to *Science* has been carried out and an updated version of the paper is pending.

### **3.2.2 TRUE-1 Continuation**

The TRUE-1 Continuation project is a continuation of the TRUE-1 experiments and the experimental focus is primarily on the TRUE-1 site. The continuation included performance of epoxy resin in Feature A at the TRUE-1 site and subsequent overcoring and analysis (TRUE-1 Completion). In addition, this project includes the production of a series of scientific articles on the TRUE-1 project, complementary laboratory sorption measurements on rim zone and fault gouge materials, and the Fault rock zones characterisation project.

The complementary laboratory work on sorption properties of fracture rim zone and fault gouge material has been complemented with some additional analyses which will enable comparison between the current results and those obtained in the site investigations.

## **Achievements**

*Fault rock zones characterisation:* During the period the final report of the Fault rock zones characterisation has been completed with the exception of a pending section on mineralogy/geochemistry, to be completed during the incoming period.

*Complementary sorption experiments:* Batch sorption measurements for cation tracers (Na, Rb, Cs, Ca, Sr, Ba, Ra and Mn) on fracture rim zone material and fault gouge materials have been performed. The fault gouge material is characterised as a strong adsorbent with significantly higher cation exchange capacity compared to crystalline rock. Supporting modelling addresses intra-granular diffusivity and the representativity of crushed material for describing the process of tracer interaction with the rock matrix. In addition, leaching results give information about the presence of natural tracers in the fault gouge and rim zone material. Comparisons are provided of the cobalthexamine and ammonium acetate methods for CEC determination and the results are discussed in relation to the results on the adsorption of cations. Finally, chemical speciation performed on the aqueous groundwater phase in the batch sorption experiments provides information on any potential degradation of the rock material taking place in the duration of a batch sorption experiment. The reporting of the complementary sorption experiments is expected to be finalised by the end of June.

### **3.2.3 TRUE-1 Completion**

TRUE-1 Completion is a sub-project of the TRUE-1 Continuation project and is a complement to already performed and ongoing projects. The main activity within TRUE-1 Completion was the injection of epoxy with subsequent overcoring of the fracture and following analyses of pore structure and, if possible, identification of sorption sites. Furthermore, several complementary in situ experiments were performed prior to the epoxy injection. These tests were aimed to secure important information from Feature A and the TRUE-1 site before the destruction of the site.

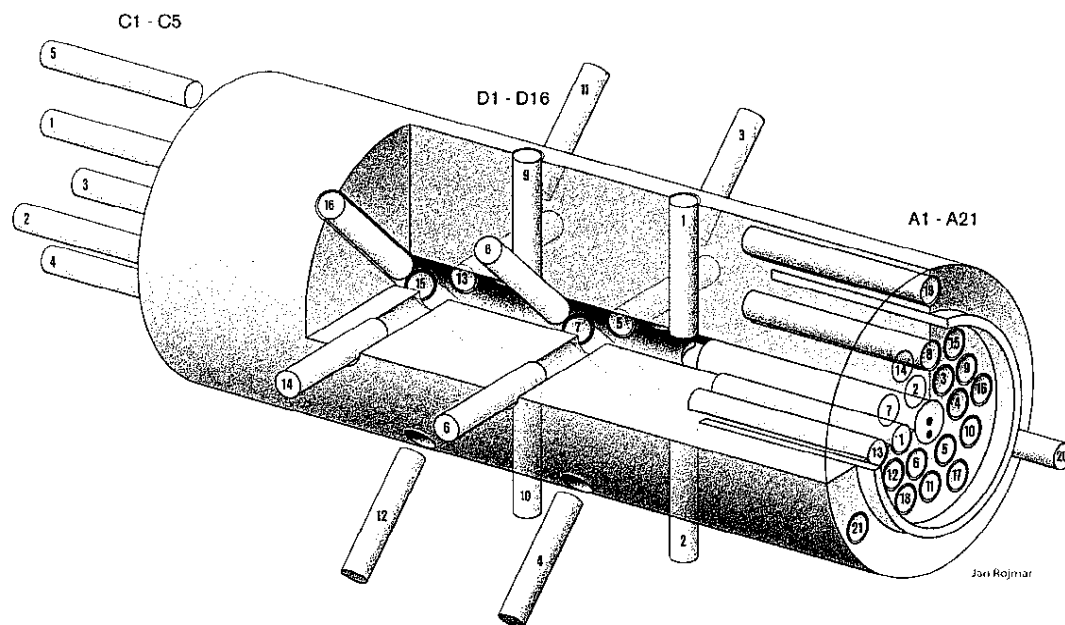
The general objectives of TRUE-1 Completion are:

- To perform epoxy injection and through the succeeding analyses improve the knowledge of the inner structure of Feature A and to improve the description and identification of the immobile zones that are involved in the noted retention.
- To perform complementary tests with relevance to the ongoing SKB site investigation programme, for instance in situ Kd- and Swiw-test (single well injection withdrawal).
- To improve the knowledge of the immobile zones where the main part of the noted retention occurs. This is performed by mapping and mineralogical-chemical characterisation of the sorption sites for Cs.
- To update the conceptual micro-structural and retention models of Feature A.

## **Achievements**

During the last four-month period, some additional mineral analyses of KXTT4 were carried out. These were possible to perform since some parts of KXTT4 only displayed low levels of radioactivity. Otherwise, the period was used for work with the reports for the three major parts of the project; tracer tests, epoxy injection with overcoring and analyses of core material. These reports will be finalised and printed during the following four-month period.

### 3.3 Long Term Sorption Diffusion Experiment



Sample cores taken out from the over core: the fracture surface on the core stub (A1 – A18), the matrix rock surrounding the small diameter extension borehole (D1 – D16), control cores taken outside core stub (A19 – A21) and beyond the test section in the small diameter borehole (C1- C5).

This experiment is performed to investigate diffusion and sorption of solutes in the vicinity of a natural fracture into the matrix rock and directly from a borehole into the matrix rock. The aims are to improve the understanding of diffusion and sorption processes and to obtain diffusion and sorption data at in situ conditions.

A core stub with a natural fracture surface is isolated in the bottom of a large diameter telescoped borehole and a small-diameter borehole is drilled through the core stub and beyond into the intact unaltered bedrock.

Tracers were circulated over a period of 6 ½ months after which the borehole was over cored. This activity is followed by analyses of tracer content.

Small diameter (24 mm) sample cores have been extracted from the 1.1 m long and 278 mm diameter large core retrieved from the over coring. 34 sample cores have been extracted both from the fracture surface on the core stub and from the matrix rock surrounding the test section in the small diameter (36 mm) extension borehole.

#### Achievements

The in-situ experiment includes measurements of the tracer concentration in the circulating groundwater in the test sections, i.e. in front of the natural fracture surface and in the small-diameter borehole in the intact unaltered bedrock. All data on the water phase activity of the 22 nuclides used, which constitutes the boundary condition for the sorption and diffusion into the rock, have been put into data tables and used for a first modelling. Models with three different approaches have been used:

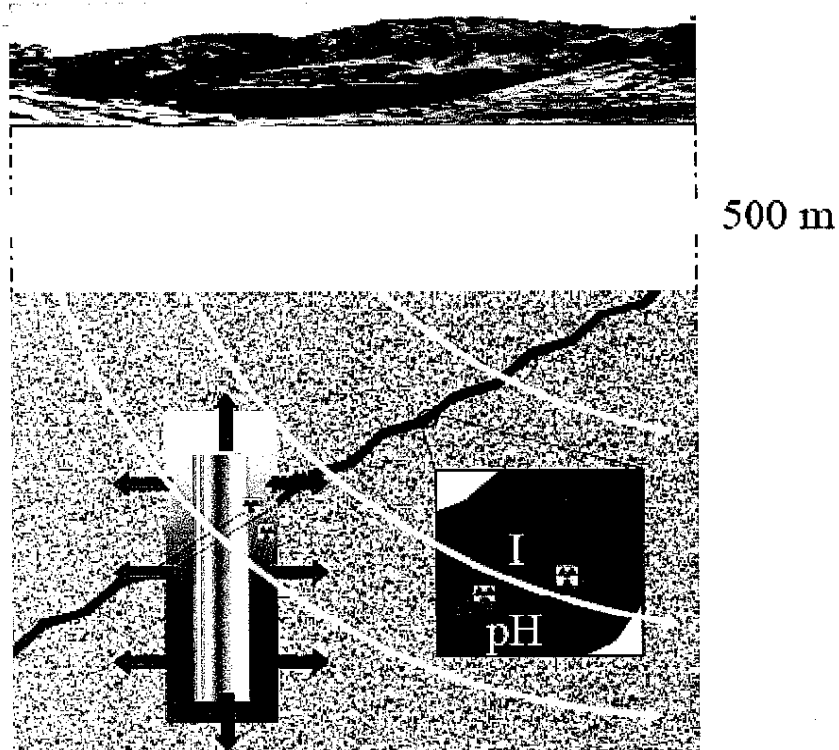
- solely matrix sorption,  $K_d$
- solely surface sorption,  $K_a$ , (since many of the tracers used are expected to adsorb by surface complexation in the very first millimetre of the fracture surface/unaltered rock)
- both  $K_d$  and  $K_a$ .

The estimated Kd values resulting from the inverse modelling are generally within the range of the Kd values determined in batch sorption experiments performed with rock samples from the LTDE-SD site, however a more thorough evaluation is underway.

The laboratory batch sorption tests and sorption/diffusion tests with intact rock pieces from the core of the small diameter extension borehole, the replica core stub and the pilot borehole core, are finalised and data tables prepared for interpretation and use in modelling. Sorption coefficients, Kd, from batch experimental data have been determined for twelve nuclide tracers, including <sup>63</sup>Ni, <sup>133</sup>Ba and <sup>137</sup>Cs. The diffusion tests on four intact rock pieces showed a rather small variation, with a mean value of  $4.6 \times 10^{-14} \text{ m}^2/\text{s}$  on the diffusion coefficient, De. Evaluation of data and determination of Kd on intact rock pieces are ongoing.

Ten sample cores drilled in the natural fracture surface on the core stub and eight sample cores drilled in the matrix rock were selected for analysis of tracer sorption and diffusion. The primary data from the crushed and intact rock slices are printed into data tables for further evaluation. Twenty-two tracers were injected in the in-situ experiment, out of which <sup>22</sup>Na, <sup>36</sup>Cl, <sup>57</sup>Co, <sup>63</sup>Ni, <sup>109</sup>Cd, <sup>110m</sup>Ag, <sup>133</sup>Ba, <sup>137</sup>Cs, <sup>157</sup>Gd, <sup>226</sup>Ra, <sup>237</sup>Np were possible to follow in the rock fabric. Species mainly sorbed by surface complexation, e.g. Gd, is found only in the first millimetres whilst Cs has penetrated typically 10 – 30 mm and Cl has penetrated up to 70 mm. Evaluation and modelling for the determination of in-situ De and Kd is ongoing.

### 3.4 Colloid Transport Project



*Colloid transport of montmorillonite colloids with or without radionuclides attached.*

The main goal for the project is to answer the questions when colloid transport has to be taken into account in the safety assessment, and how the colloid transport can be predicted in modelling.

In the beginning of the lifetime of a deep bedrock repository the groundwater will be quite saline and montmorillonite as well as natural colloids are not stable. Therefore colloid transport can be neglected during this time period.

In the scenario of intrusion of dilute glacial meltwater the conditions for colloid stability can drastically change. Bentonite erosion may give conditions for transport away from the barrier giving loss of material leading to a decrease in the barrier functionality. Also, in the scenario of a leaking canister, strongly sorbed radionuclides to montmorillonite colloids may be transported out from the barrier. Even if the conditions are such that bentonite erosion is favourable, it is not necessarily so that the transport out from the barrier is fast. Retention mechanisms as physical filtration and sorption may significantly reduce the mobility of the colloids.

#### **Achievements**

Mockup tests of erosion and generation of Na- and Ca-montmorillonite show that the gel propagation is significantly affected by the groundwater composition. The difference between gel propagation rate in a dilute water and Grimsel groundwater, with 0.001 M Na and 0.0001 M Ca is large. Ca-bentonite acts as expected very differently from Na-bentonite. The montmorillonite colloid concentrations outside a bentonite barrier will be at least one magnitude lower in the contact with Grimsel groundwater compared to deionised water. A manuscript with the results is under preparation.

Bentonite erosion experiments have been performed in the Quarried Block, in a well-defined fracture, with MX-80 in contact with Grimsel groundwater. Compacted bentonite plugs mixed with fluorescent latex colloids were installed in the block where after synthetic Grimsel groundwater was introduced with a flow rate of approximately

$10^{-6}$  m/s. The gel propagation acted very similar to earlier experiments with similar conditions in a synthetic plexiglas fracture. Very low colloid concentrations reached the sampling outlets and the major part of the bentonite mass remained in the plugs. This indicates no or extremely slow bentonite erosion in this specific system. A report and manuscript are under preparation.

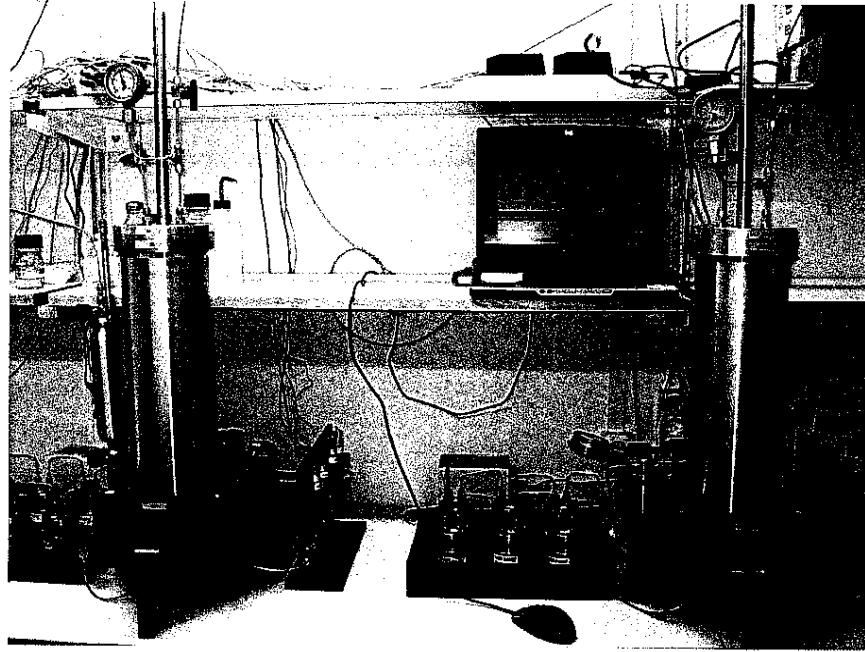
Sorption experiments of latex and montmorillonite colloids on fracture filling materials such as quartz and biotite have been performed in 0.001 M ionic strength and in the pH range 4-10 to study sorption of colloids in favourable and less favourable conditions. Sorption of both latex and montmorillonite was observed even in unfavourable conditions, and can, as expected, be explained by electrostatic interactions. The sorption was significantly higher to minerals such as biotite, compared to for example quartz, and the rationale is the point of zero charge at a higher pH.

In addition, transport experiments with latex- and montmorillonite colloids in columns with different types of filling minerals, have been performed to study retention mechanisms such as sorption and filtration of colloids. The retention is higher in columns including biotite. During the experimental time the latex colloids seems to be irreversibly but the montmorillonite colloids reversibly retained in the columns. The results are currently being modelled with Colloid Filtration Theory and two manuscripts have been sent to scientific journals for review.

### **3.5 Microbe Projects**

Microorganisms interact with their surroundings and in some cases they greatly modify the characteristics of their environment. Several such interactions may have a significant influence on the function of a repository for spent fuel /Pedersen 2002/. There are presently four specific microbial process areas identified that are of importance for proper repository functions. They are: bio-mobilisation of radionuclides, bio-immobilisation of radionuclides, microbial effects on the chemical stability of deep groundwater environments and microbial corrosion of copper.

The study of microbial processes in the laboratory gives valuable contributions to our knowledge about microbial processes in repository environments. However, the results obtained by laboratory studies must be tested in a repository like environment. The reasons are several. Firstly, at repository depth, the hydrostatic pressure reaches close to 50 bars, a setting that is very difficult to reproduce in the laboratory. The high pressure will influence chemical equilibrium and the content of dissolved gases. Secondly, the geochemical environment of deep groundwater, on which microbial life depends and influence, is complex. Dissolved salts and trace elements, and particularly the redox chemistry and the carbonate system are characteristics that are very difficult to mimic in a university laboratory. Thirdly, natural ecosystems, such as those in deep groundwater, are composed of a large number of different species in various mixes /Pedersen 2001/. The laboratory is best suited for pure cultures and therefore the effect from consortia of many participating species in natural ecosystems cannot easily be investigated there. The limitations of investigations arrayed above in a laboratory situated on ground have resulted in the construction and set-up of an underground laboratory in the Äspö HRL tunnel. The site is denoted the Microbe Laboratory and is situated at the -450 m level, see below.



*Pressure resistant micro-electrodes are used to analyse redox and pH in the circulation systems.*

The Microbe Laboratory has been installed in the Äspö HRL for studies of microbial processes in groundwater under in situ conditions.

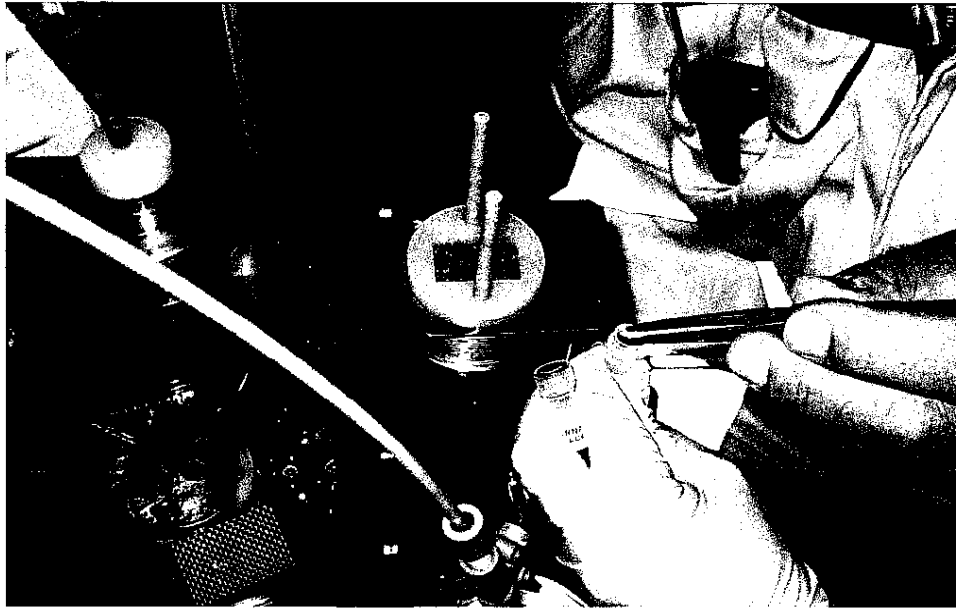
The Microbe site is on the -450 m level where a laboratory container with benches and an advanced climate control system is located.

Three boreholes, KJ0050F01, KJ0052F01 and KJ0052F03, intersecting water conducting fractures are connected to the Microbe Laboratory via tubing. The laboratory is equipped with six circulation systems offering 2,112 cm<sup>2</sup> of test surface per system.

The major objectives are to:

- Offer proper circumstances for research on the effect of microbial activity on the long-term chemical stability of the repository environment.
- Provide in situ conditions for the study of bio-mobilisation of radionuclides.
- Present a range of conditions relevant for the study of bio-immobilisation of radionuclides.
- Enable investigations of bio-corrosion of copper under conditions relevant for a high level radioactive waste repository.
- Constitute a site for research within other projects that require an underground site for microbiological investigations.

### 3.5.1 Micored



*Sampling of rock pieces that have been exposed in a flow cell to circulating groundwater in one of the circulation systems on the Microbe site. Subsequently, DNA analysis reveals amount and types of microorganisms that have attached and grown on the rock pieces.*

Microorganisms can have an important influence on the chemical situation in groundwater. Especially, they may execute reactions that stabilise the redox potential in groundwater at a low level.

It is hypothesised that hydrogen and possibly also methane from deep geological processes contributes to the redox stability of deep groundwater via microbial turnover of this gas. These metabolisms will generate secondary metabolites such as ferrous iron, sulphide, acetate and complex organic carbon compounds.

The work within the Micored project will:

- Clarify the contribution from microorganisms to stable and low redox potentials in groundwater.
- Demonstrate and quantify the ability of microorganisms to consume oxygen in the near- and far-field areas.
- Explore the relation between content and distribution of gas and microorganisms in deep groundwater.

### **Achievements**

Two series of experiments were completed during 2009 where the influence of hydrogen, acetate and lactate on growth of sulphate reducing bacteria (SRB) was investigated with groundwater from KJ0050F01 and KJ0052F01. The growth was followed by analysis of DNA specific for SRB and gases. Redox potential was analysed with microelectrodes and with field electrodes. The experiments were successful and data analysis is presently ongoing. A third series was started in March 2010, where the influence of hydrogen on microbial processes was investigated. A fourth series will be started in May, where the influence of pulses of oxygen is investigated on 6 different configurations sulphate reducing bacteria systems.

### 3.5.2 Micomig



*Drill cores with fractures from drill site KA1362A in the Äspö HRL tunnel.*

*Upper left: Fracture surface at the 4.3 m position in drill hole KA1362A-6 showing calcite crystals mixed with grey and black minerals.*

*Lower left: Fracture surface at the 4.7 m position in drill hole KA1362A-6 showing large amounts of white calcite on top of black iron-sulfide precipitates. Sulfate-reducing bacteria were detected in this fracture by cloning and sequencing.*

*Upper right: Fracture surface at the 2.5 m position in drill hole KA1362A-6 showing large amounts of green and dark red minerals.*

*Lower right: Fracture surface at the 0.8 m position in drill hole KA1362A-2 showing black minerals. Calcite crystals were observed as well.*

It is well known that microbes can mobilise trace elements. Firstly, unattached microbes may act as large colloids, transporting radionuclides on their cell surfaces with the groundwater flow. Secondly, microbes are known to produce ligands that can mobilise soluble trace elements and that can inhibit trace element sorption to solid phases.

Almost all microorganisms are attacked by viruses. A successful attack may result in several hundred new viruses. The size of virus is well within the range of colloids. The influence of such viruses on colloid related processes can be significant, as the numbers of viruses in groundwater may reach several billion particles per litre.

Biofilms in aquifers will influence the retention processes of radionuclides in groundwater. Previous research at Äspö HRL indicated that biofilms may enhance or retard sorption, depending on the radionuclide in question.

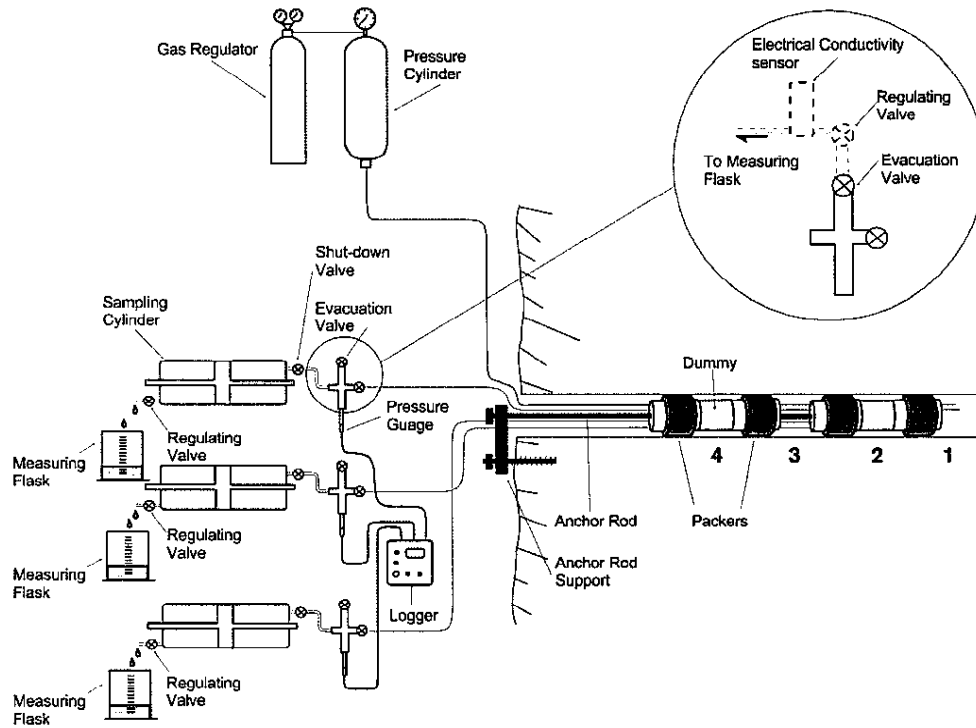
The major objectives are to:

- Evaluate the influence from microbial complexing agents on radionuclide migration.
- Explore the influence of microbial biofilms on radionuclide sorption and matrix diffusion.
- Analyse the possibility of a colloidal effect from viruses in groundwater on radionuclide mobility.

## **Achievements**

Six drill cores were drilled and retrieved from 186 m depth in the Äspö HRL tunnel to investigate whether biofilms develop on fracture surfaces in groundwater-conducting aquifers in granitic rock. DNA was extracted from sampled fracture surface material (FSM), amplified, and cloned; 231 clones were sequenced for diversity analysis. Real-time (RT) quantitative PCR was applied to quantify biomass using the 16S rRNA gene for domain Bacteria and the adenosine-phosphosulfate reductase gene (*apsA*) for sulfate-reducing bacteria (SRB). Results were compared with data from three groundwater systems with biofilms in laminar flow reactors (LFRs) at 450 m depth in the Äspö HRL. The total number of cells, counted microscopically, was approximately  $2 \times 10^5$  cells  $\text{cm}^{-2}$  in the LRF systems, consistent with the obtained RT-PCR 16S rRNA gene values. RT-PCR analysis reported  $\sim 1 \times 10^2$  up to  $\sim 1 \times 10^4$  standard cell units  $\text{cm}^{-2}$  on the FSM from the drill cores. In the FSM biofilms, 33% of the 105 sequenced clones were related to the iron-reducing bacterium *Stenotrophomonas maltophilia*, while in the LRF biofilms, 41% of the 76 sequenced clones were affiliated with the dominant genera *Desulfovibrio*, *Desulforhopalus*, *Desulfomicrobium*, and *Desulfobulbus*. The clone diversity of the FSM biofilms differed from that of the drill water, excluding drill water contamination of the biofilms. This work reports significant numbers of microorganisms on natural hard rock aquifer fracture surfaces with significant, site-specific diversities. The probability that biofilms are generally present in groundwater-conducting aquifers in deep granitic rock is consequently great.

### 3.6 Matrix Fluid Chemistry Continuation



The main objectives of the Matrix Fluid Chemistry experiment are to understand the origin and age of fluids/groundwater in the rock matrix pore space and in micro-fractures, and their possible influence on the chemistry of the groundwater from the more highly permeable bedrock. Matrix fluids are sampled from a borehole drilled into the rock matrix. Fluid inclusions in core samples have also been studied to determine their contribution, if any, to the composition of the matrix fluids/groundwater.

A first phase of the project is finalised and reported /Smellie et al. 2003/. The major conclusion is that porewater can successfully be sampled from the rock matrix and there is no major difference in chemistry compared to groundwater from more highly conductive fracture zones in the near-vicinity.

#### **Achievements**

No work has been performed within the project during the first four month period of 2010.

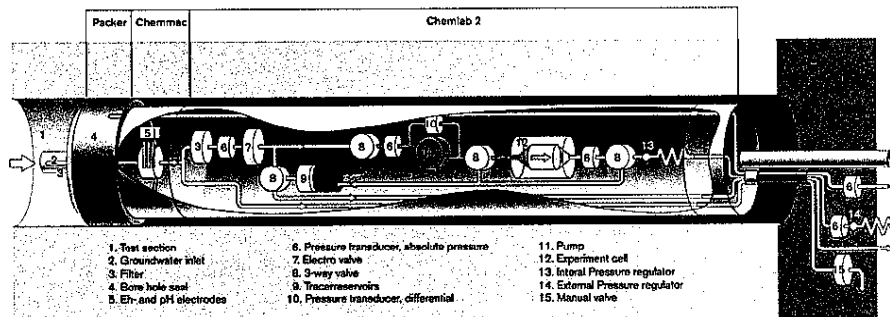
A continuation phase of the project started 2004 with the aim to focus on areas of uncertainty which remain to be addressed:

- The nature and extent of connected porewaters in the Äspö bedrock.
- The nature and extent of the microfracture groundwaters which penetrate the rock matrix and the influence of these groundwaters on the chemistry of the porewaters.
- The confirmation of rock porosity values previously measured in the earlier studies.

### 3.7 Radionuclide Retention Experiments

Most of the Radionuclide Retention Experiments that have been and are planned to be carried out, have the aim to confirm results of laboratory studies in situ, where natural conditions prevail concerning e.g. redox conditions, contents of colloids, organic matter and bacteria in the groundwater. The experiments are performed in two different unique borehole laboratories, Chemlab 1 and Chemlab 2. The Chemlab probes contain a number of valves, pumps, fraction collectors, etc., all to make it possible to perform a set of different experiments.

#### 3.7.1 Spent Fuel Leaching



Principal drawing of Chemlab 2.

In the Spent Fuel Leaching experiments, to be performed within the framework of the programme for in situ studies of repository processes, the dissolution of spent fuel in groundwater will be studied.

The objectives of the experiments are to:

- Investigate the leaching of spent fuel in laboratory batch experiments and under in situ conditions.
- Demonstrate that the laboratory data are reliable and correct for the conditions prevailing in the rock.

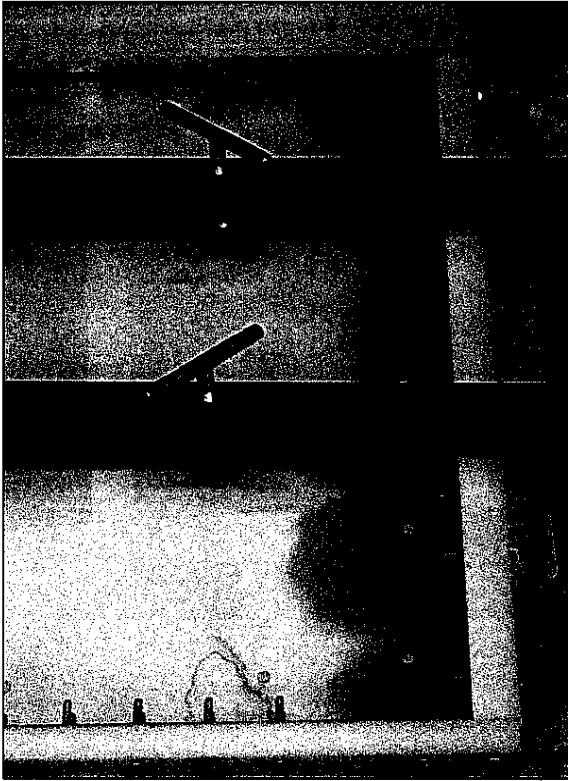
The in situ experiments will be preceded by laboratory experiments where the scope is both to examine parameters that may influence the leaching as well as testing the equipment to be used in the field experiments.

In the field experiments spent fuel leaching will be examined with the presence of  $H_2$  (in a glove box situated in the gallery) as well as without the presence of  $H_2$  (in Chemlab 2).

#### Achievements

Due to priorities within SKB the project has been severely delayed and hence no longer considered relevant. The project will formally be finalised during 2010 and no further work will be carried out.

### 3.7.2 Transport Resistance at the Buffer-Rock Interface



*The expansion of bentonite into an artificial fracture.*

If a canister fails and radionuclides are released, they will diffuse through the bentonite buffer. If there is a fracture intersecting the deposition hole, the water flowing in the fracture will pick up radionuclides from the bentonite buffer.

The transport resistance is concentrated to the interface between the bentonite buffer and the rock fracture. The mass transfer resistance due to diffusion resistance in the buffer is estimated to only 6% while the diffusion resistance in the small cross section area of the fracture in the rock to 94%. The aim of the project is to perform studies to verify the magnitude of this resistance.

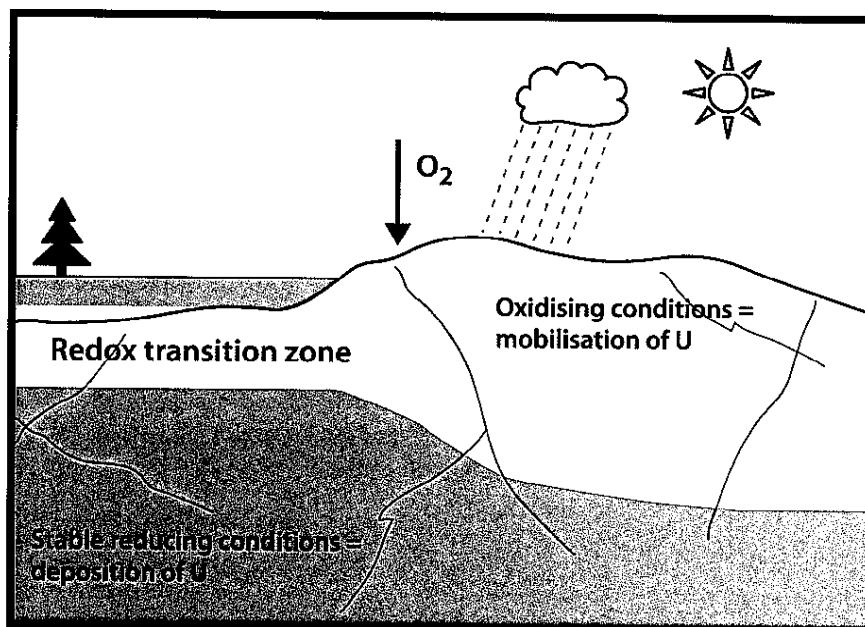
The experiment will be performed in the laboratory, where a fracture is simulated as a 1 mm 'fracture' between two Plexiglas plates. The equipment for the laboratory experiments has been used in the Bentonite Erosion project.

The equipment includes a water pump for very low flow rates. The design of field experiments depends on the outcome of the laboratory experiments.

#### **Achievements**

Due to priorities within SKB the project has been severely delayed and hence no longer considered relevant. The project will formally be finalised during 2010 and no further work will be carried out.

### 3.8 Padamot



*Oxygen entering the bedrock via recharge water will be consumed by organic and inorganic processes along the bedrock fractures. This transition can be detected by studies of uranium and uranium isotopes.*

Padamot (Palaeohydrogeological Data Analysis and Model Testing) investigates changes in groundwater conditions as a result of changing climate. Because the long term safety of an underground repository depends on the stability of the repository environment, demonstration that climatic impacts attenuate with depth is important. Currently, scenarios for groundwater evolution relating to climate changes are poorly constrained by data and process understanding.

The EC-part of the project was finalised and reported in 2005. The Padamot continuation project comprises:

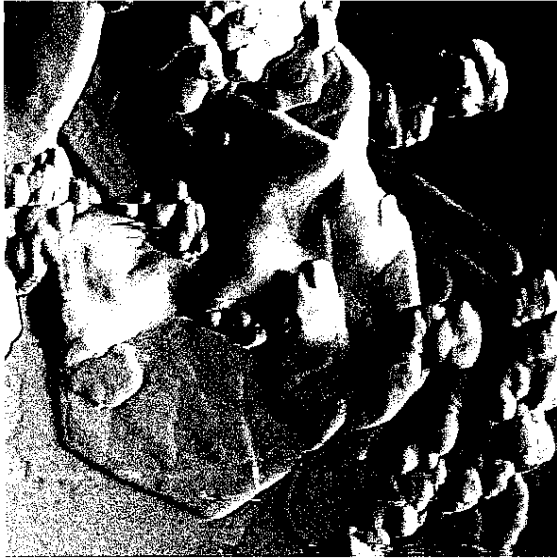
- Further developments of analytical techniques for uranium series analyses applied on fracture mineral samples and inter-laboratory comparisons.
- The use of these analyses for determination of the redox conditions during glacial and postglacial time.
- A summary of the experiences from the palaeohydrogeological studies carried out at Äspö.

The analyses are carried out on split samples of fracture material from a surface borehole drilled at Äspö (KAS17). This borehole penetrates the large E-W fracture zone called the Mederhult zone.

#### **Achievements**

There has been no activity in this project during the first four month period of 2010 due to SKB's priority of SR-site.

### 3.9 Fe-oxides in Fractures



*Atomic Force Microscopy image of green rust sulphate. Image is 2.5 x 2.5 microns.*

Proof of reducing conditions at repository depth is fundamental for the safety assessment of radioactive waste disposals. Fe(II) – minerals are common in the bedrock and along fracture pathways and constitute a considerable reducing capacity together with organic processes. Another area of interest is the radionuclide retention capacity provided by Fe-oxides and –oxyhydroxides in terms of sorption capacity and immobilisation.

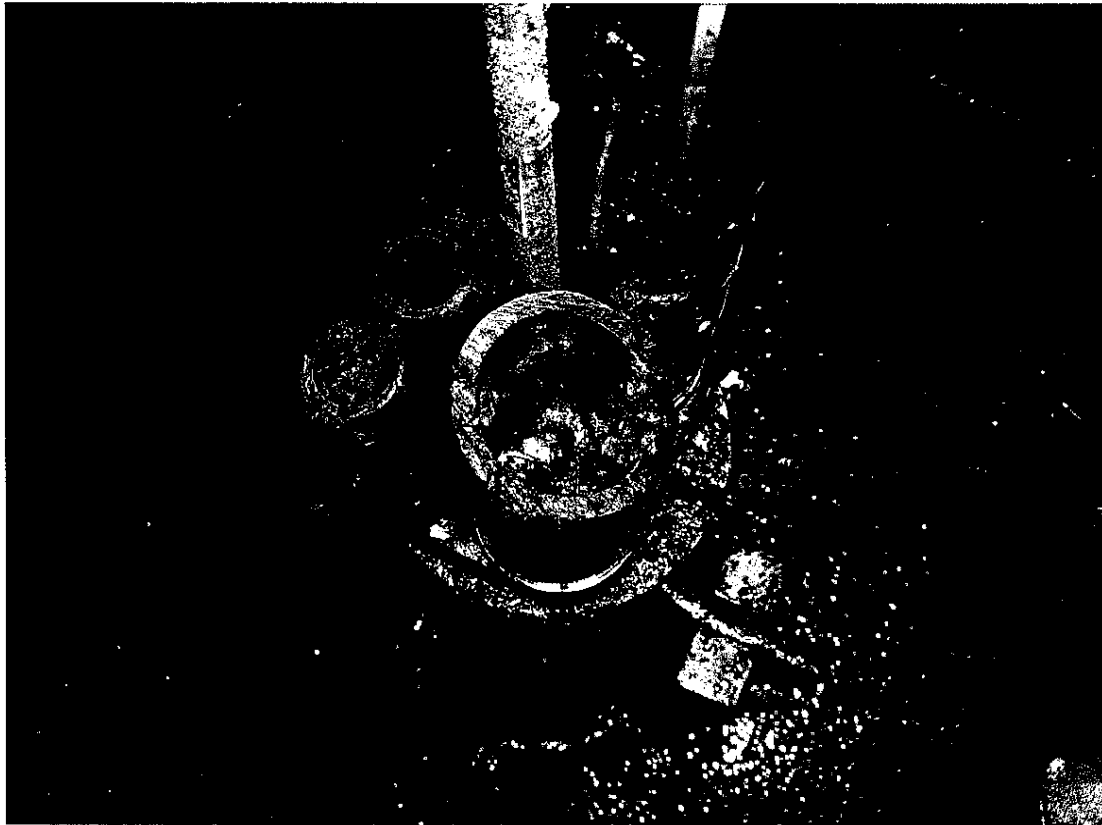
The basic idea of the project is to examine Fe-oxide fracture linings, in order to explore for suitable palaeo-indicators for their formation conditions, while at the same time learning about the behaviour of trace component uptake in general, both from the natural material as well as through testing of behaviour in controlled parametric studies in the laboratory.

Following the original project, a continuation phase with the aim to establish the penetration depth of oxidising water below ground level was started. The oxidising waters may represent present-day recharge, or reflect penetration of glacial melt waters during the last glaciation.

#### **Achievements**

No work has been performed within the project during the first four months of 2010.

### 3.10 Investigation of Sulphide Production Processes in Groundwater



*Black precipitate and a strong smell of hydrogen sulphide gas in the standpipes of borehole KAS03. The borehole equipment (iron bars, plastic tubing and rubber packers) was installed more than 20 years ago for groundwater and pressure monitoring purposes.*

Elevated sulphide concentrations in groundwater have been observed in some boreholes during the site investigations at Laxemar and Forsmark as well as in boreholes investigated during the pre-investigation phase at Äspö. Since sulphide can react with the copper canister, assessment of the variation of sulphide in space and time is of outmost importance in the waste disposal programme. Sulphate reduction at temperatures and pressures prevailing in deep groundwater environment is a microbiological process. Sulphate reducing bacteria (SRB) use the S atom in the sulphate molecule as an electron-acceptor and the reduced product is hydrogen sulphide. The energy and electron donor for SRB can be hydrogen or organic compounds such as methane, acetate, photosynthetic organic carbon or leaching carbon from equipment details.

The project is proposed to meet the demand for a better understanding of the processes behind microbial sulphate reduction in core drilled boreholes and also to assess any possible influence of the borehole and borehole equipment on the sulphide concentration.

Core drilled boreholes are equipped for monitoring purposes. The equipments are manufactured from stainless steel, iron, different kinds of plastics and rubber. The water standpipes constitute the part of the borehole equipment with a range from the ground level to up to tens of meters down. A plastic tubing connects the water in the standpipe to the water in the section.

Overall, the composition of water in the standpipe is different from that in the borehole section. It contains for example more organic material and dissolved and particulate sulphide. When sampling section water, a portable pump (connected to an empty tubing) is lowered down to the bottom of the standpipe. The water and precipitate in the standpipe is then a possible source of contamination during water sampling. In addition, differences in water composition may create chemical gradients that give rise to chemical and microbiological reactions.

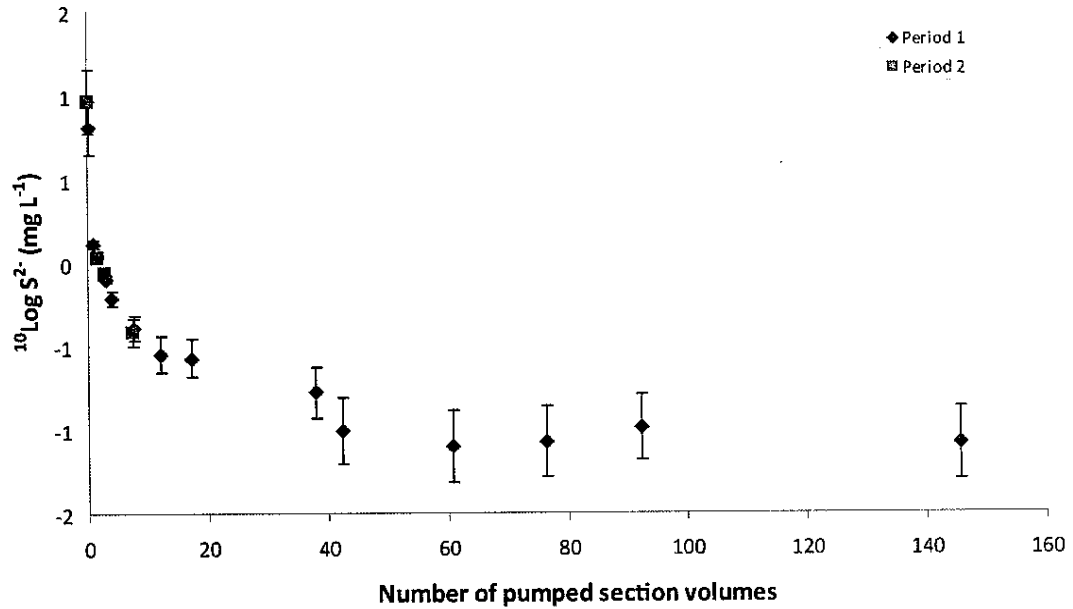
## **Achievements**

Analysis data from the field investigations in KLX06, KAS03 and KAS09 have been evaluated and compiled in a draft final project report.

A pre-study including functionality test of equipment and analysis of sulphide was performed in two borehole sections in Äspö HRL (KA3110A:1 and KA3385A:1). The subsequent main study is focused on understanding more about the processes involved in microbial sulphide production in core drilled boreholes and is part of the project KBP4001.

The main results and conclusions from the investigations are summarised as follows:

- Elevated concentrations of sulphide and sulphate- and iron-reducing bacteria were found in core drilled boreholes with stagnant water, both in the standpipe and in borehole section. Continuous discharge of water through pumping resulted in decreasing concentrations. The concentrations were again restored after an interruption in the pumping of about 2 months (Figure 3-2).
- The standpipe is possibly a source of contamination during water sampling and analysis due to its high concentrations of sulphide and dissolved organic carbon. In addition different water compositions in standpipe and section may create chemical gradients that give rise to chemical and microbiological reactions (such as production of sulphide).
- Gases that influence microbial activity (methane, hydrogen and carbon dioxide) decreased in concentration during pumping, i.e. the gases build up in concentration during periods when pumping is not performed. Other gases, such as nitrogen, were unchanged.
- The isotope signatures of  $\delta^2\text{H}$  and  $\delta^{13}\text{C}$  in methane suggest that the methane is produced in abiogenic processes. The isotope signatures of  $\delta^{13}\text{C}$  and pmC in hydrogen carbonate suggest that the hydrogen carbonate originate from more than one carbon source.



**Figure 3-2** *10Log S<sub>2</sub><sup>-</sup> versus number of discharged section volumes in KLX06 from two pumping periods. A two-month break in the pumping was carried out between period 1 and 2. The sulphide concentration was restored after the two-month break.*

The future main task will be to clarify which of the possible electron donors hydrogen, methane, acetate, photosynthetic organic carbon or leaching carbon from installations support the microbial sulphide producing process. Based on the results from this project the development of parameters that are involved in sulphide production should be followed between periods of pumping.

### 3.11 Swiw-tests with Synthetic Groundwater



*Injection of tracer in fracture.*

The Single Well Injection Withdrawal (Swiw) tests with synthetic groundwater constitute a complement to performed tests and studies on the processes governing retention, e.g. the TRUE experiments as well as Swiw tests performed within the SKB site investigation programme.

The general objective of the Swiw test with synthetic groundwater is to increase the understanding of the dominating retention processes and to obtain new information on fracture aperture and diffusion. The basic idea is to perform Swiw tests with synthetic groundwater with a somewhat altered composition, e.g. replacement of chloride, sodium and calcium

with nitrate, lithium and magnesium, compared to the natural groundwater at the site.

Sorbing as well as non-sorbing tracers may be added during the injection phase of the tests. In the withdrawal phase of the tests the contents of the "natural" tracers (chloride sodium and calcium) as well as the added tracers in the pumping water is monitored. The combination of tracers, both added and natural, may then provide desired information on diffusion, for example if the diffusion in the rock matrix or in the stagnant zones dominates.

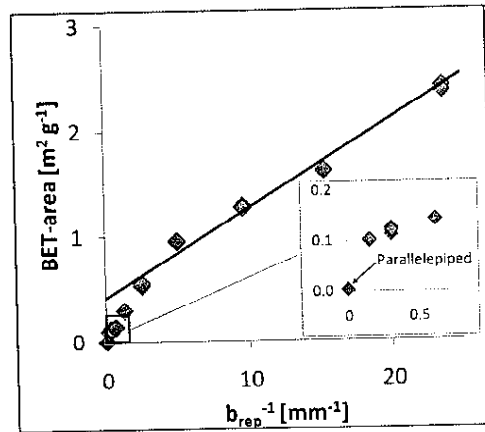
#### **Achievements**

Early during the last four-month period the activity plan for the field tests in KA2858A was approved. The field work initiated with hydraulic tests, groundwater flow measurements and chemistry sampling in order to further evaluate the suitability of KA2858A as a test site for Swiw with synthetic groundwater. The fall out of these tests were considered as favourable for the continuation of the project at the site. After a re-installation of the borehole equipment, in order to reduce the test section volume, a Swiw pre-test without waiting period was carried out. In this test, groundwater from the test section was used together with a conservative tracer. In general, the equipment worked well and a high tracer recovery was achieved in the test. Consequently and according to plan, a second Swiw pre-test with a waiting period was initiated thereafter. This test is still on-going and no results are available at this time.

### 3.12 Äspö Model for Radionuclide Sorption



A chunk of chlorite.



The specific surface area [ $m^2 g^{-1}$ ] of chlorite as function of the inverse of the characteristic particle size [ $mm^{-1}$ ]. The enlarged part of the plot shows results for larger particles.

Today, geochemical retention of radionuclides in the granitic environment is commonly assessed using Kd-modelling. However, this approach relies on fully empirical observations and therefore contributes to the conceptual understanding of reactive transport in complex rock environments only to a limited degree.

In the literature, the process based Component Additivity (CA) approach, which relies on a linear combination of sorption properties of different minerals in a geological material, has been suggested for estimation of sorption properties.

For adoption of this approach to granitic material, the particle size/surface area dependence of radionuclide sorption and effects of grain boundaries need to be resolved. Furthermore, it is desirable to verify possible localised sorption of radionuclides to specific minerals within the rock.

The overall objective of this project is to formulate and test process quantifying models for geochemical retention of radionuclides, in granitic environments, using a combined laboratory and modelling approach. The ambition is to include experimental data for specific surface area and sorption capacity for each of the mineral phases that constitutes granitic rock into the model.

#### Achievements

During the first four month of 2010 determinations of the specific surface area of each size fraction of mineral samples were continued. In the BET-method, an inert gas ( $N_2(g)$  or  $Kr(g)$ ) is sorbed to the surface of a substrate with known mass, and the sorption data is interpreted in terms of available surface area of the sample.

The two minerals K-feldspar and chlorite were studied, showing somewhat different behaviours than the previously investigated labradorite and magnetite. Both K-feldspar, which is a three dimensional tectosilicate, and chlorite, which is a two dimensional phyllosilicate, are common minerals at Äspö. Chlorite particularly occurs as an alteration product of biotite in and close to fractures. Chlorite is one of the major iron containing minerals at the site, and potentially an important sorbent for radionuclides, see e.g. /Malmström et al. 2010/.

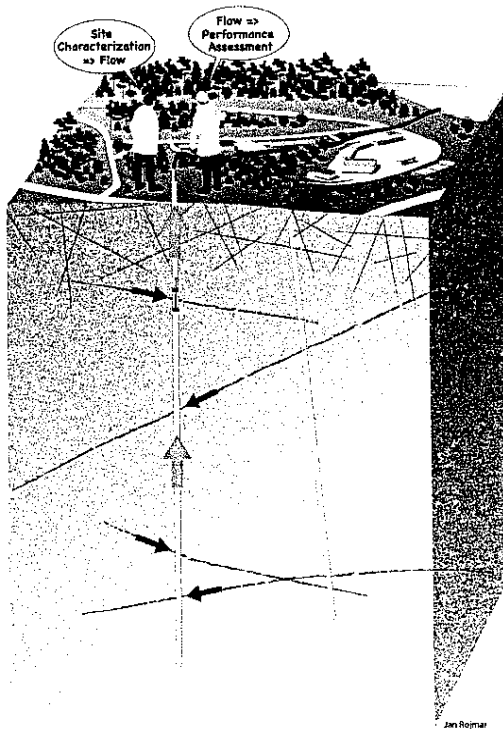
For both minerals it was found, as expected, that the specific surface area increases with decrease in the characteristic size of the particles. For chlorite, a linear increase of the specific surface area with the inverse of the particle size was observed for particles smaller than 200-300  $\mu\text{m}$ . Similarly, for K-feldspar such a linear increase was observed for all particles studied (up to 8 mm). For larger particles of chlorite (characteristic particle size,  $b_{\text{rep}}^{-1} < 3\text{-}5 \text{ mm}^{-1}$  in the figure at right above), a negative deviation from this linear trend was observed.

For chlorite, a much lower specific surface area was measured on large mineral parallelepiped of  $3 \times 3$  cm basis, and about 5 cm long, than expected from extrapolation of experimental results of the smaller particles (see insert to the figure above). For the K-feldspar, the specific surface area of the parallelepiped was even below the detection limit of the instrument used. The negative deviation from the linear trend of the surface area with inverse of the particle size and the much lower specific surface area of large parallelepipeds were tentatively attributed to a mechanically disturbed zone at the particle edge, as discussed by /Dubois et al. 2010/. This suggests that for small particles, the entire volume of the particle is affected by sample excavation and powder preparation, with this mechanical treatment resulting in additional microfractures in the material, and the exposure of fresh mineral surfaces, not present in the pristine material, see /André et al. 2009 and Dubois et al. 2009, 2010/. As discussed by /André et al. 2009/ and /Dubois et al. 2009, 2010/, this additional surface area with potentially fresh and more reactive surfaces dominates in particle size fractions usually employed in laboratory studies of sorption.

During the first four months of 2010, porosity determinations on the pure mineral parallelepipeds using nitrogen gas adsorption has been initiated, and currently the method is being developed and tested. Mineral samples of apatite and pyrite have also been prepared for surface area and porosity measurements. Furthermore, a literature review, aiming at compiling surface complexation and ion-exchange models for sorption on Eu, Ni, Co, Cs and Sr on pure, granitic minerals under laboratory conditions and identifying important knowledge gaps, has been continued.

Results from the experimental work on the specific surface area of K-feldspar and chlorite has been summarised in a conference article /Dubois et al. 2010/ which has been accepted for presentation at the 13<sup>th</sup> Water Rock Interaction Conference in Guanajuato, Mexico, 16<sup>th</sup> -20<sup>th</sup> of August, 2010.

### 3.13 Task Force on Modelling of Groundwater Flow and Transport of Solutes



*Task 7 - Reduction of Performance Assessment uncertainty through modelling of hydraulic tests at Olkiluoto, Finland.*

The Åspö Task Force on Modelling of Groundwater Flow and Transport of Solutes is a forum for the organisations supporting the Åspö HRL to interact in the area of conceptual and numerical modelling of groundwater flow and transport of solutes in fractured rock.

The Task Force shall propose, review, evaluate and contribute to the modelling work in the project. In addition, the Task Force shall interact with the principal investigators responsible for carrying out experimental and modelling works for Åspö HRL.

The work within the Task Force constitutes an important part of the international co-operation within the Åspö HRL.

#### **Achievements**

During the first four-month period of 2010, work has mainly been performed in Task 7 and Task 8. Task 7 - Reduction of Performance Assessment uncertainty through modelling of hydraulic tests at Olkiluoto, Finland - is focusing on methods to quantify uncertainties in PA-type approaches based on SC-type information; along with being an opportunity to increase the understanding of the role of fracture zones as boundary conditions for the fracture network and how compartmentalisation influence the groundwater system. The possibilities to extract more information from interference tests will also be addressed. The status of the specific modelling tasks within Task 7 is given within brackets in Table 3-1.

Task 8 is addressing the interaction between the bentonite and the rock. Furthermore, Task 8 is a joint effort with the Task Force on Engineered Barriers, and will therefore be addressing the processes at the interface between the rock and the bentonite in deposition holes. The performed work in Task 8 includes planning, administration, task definitions, and scoping calculations.

A workshop on Task 7 and 8 was held in January, and the venue took place at the Vuojoki mansion in Finland. The minutes have been distributed. Planning for the 26<sup>th</sup> Task Force meeting in Spain has been on-going.

**Table 3-1 Descriptions and status (within brackets) of the specific modelling sub-tasks with Task 7 - Reduction of Performance Assessment uncertainty through modelling of hydraulic tests at Olkiluoto, Finland.**

---

<b>7</b>	<b>Reduction of Performance Assessment uncertainty through modelling of hydraulic tests at Olkiluoto, Finland.</b>
7A	Long-term pumping experiment. (Final results of sub-task 7A1 and 7A2 are reported as ITDs).
7B	Sub-task 7B is addressing the same as sub-task 7A but in a smaller scale, i.e. rock block scale. Sub-task 7B is using sub-task 7A as boundary condition. (Updated results presented at the Vuojoki workshop).
7C	Here focus is on deposition hole scale issues, resolving geomechanics, buffers, and hydraulic views of fractures. (Updated results presented at the he Vuojoki workshop).
7D	Tentatively sub-task 7D concerns integration on all scales (Tentative).

---

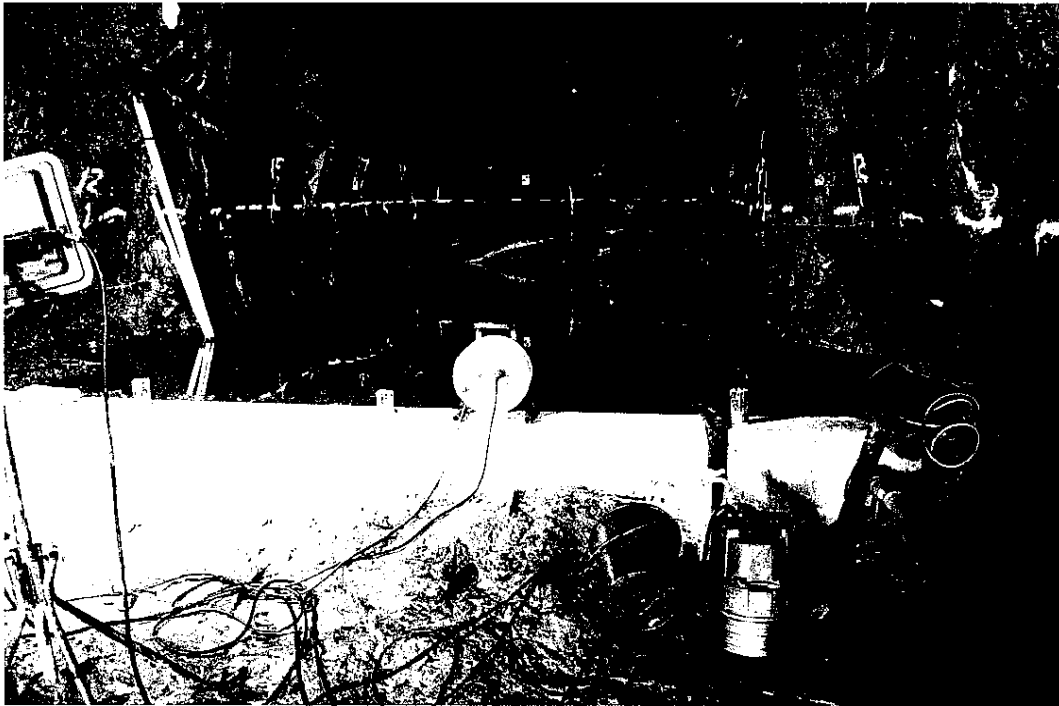


## 4 Engineered barriers

### 4.1 General

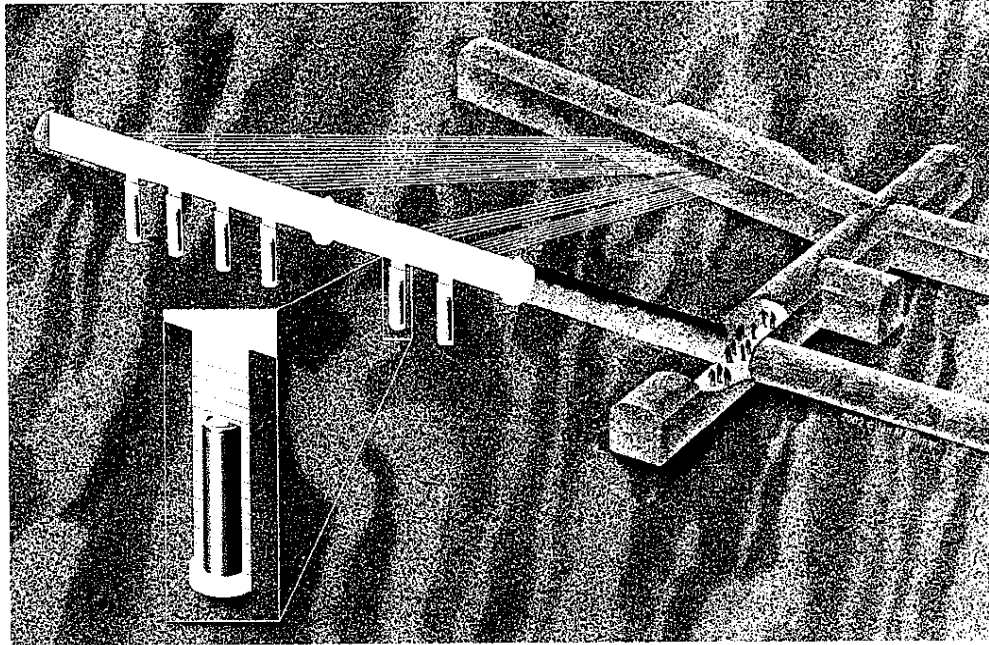
Another goal for Äspö HRL is to demonstrate technology for and function of important parts of the repository system. This implies translation of current scientific knowledge and state-of-the-art technology into engineering practice applicable in a real repository. It is important that development, testing and demonstration of methods and procedures, as well as testing and demonstration of repository system performance, are conducted under realistic conditions and at appropriate scale.

A number of large-scale field experiments and supporting activities are therefore conducted at Äspö HRL, see Figure 4-1. The experiments focus on different aspects of engineering technology and performance testing, and together, form a major experimental programme.



*Figure 4-1 Water filled measuring weir in the project Sealing of Tunnel at Great Depth.*

## 4.2 Prototype Repository



The Prototype Repository is located in the TBM-tunnel at the -450 m level and includes six full scale deposition holes. The aims of the Prototype Repository are to demonstrate the integrated function of the repository components and to provide a full-scale reference for comparison with models and assumptions.

The Prototype Repository should, to the extent possible, simulate the real repository system regarding geometry, materials and rock environment.

The inner tunnel (Section I, canisters #1-#4) was installed and the plug cast in 2001 and the heaters in the canisters were turned on one by one. The outer tunnel (Section II, canisters #5-#6) was backfilled in June 2003 and the tunnel plug with two lead-troughs was cast in September the same year. The surface between the rock and the outer plug was grouted in October 2004 and the drainage of the tunnel was closed at the beginning of November.

Installed instrumentation is used to monitor processes and properties in the canister, buffer material, backfill and the near-field rock. The evolution will be followed for a long time.

### **Achievements**

The data collection system comprises temperature, total pressure, pore water pressure, relative humidity and resistivity measurements in buffer and backfill, as well as temperature and water pressure measurements in boreholes in the rock around the tunnel. The collection of data is in progress and the data report No. 22 covering the period up to November 2009 has been published /Goudarzi and Johannesson 2009/. Overhauling of the data acquisition system is in progress.

Acoustic Emission and Ultrasonic monitoring from the rock around deposition hole 5 and 6 is continuing. Two reports covering the measuring periods October 2008 to March 2009 and April 2009 to September 2009 have been finalised and will be published as IPR-reports.

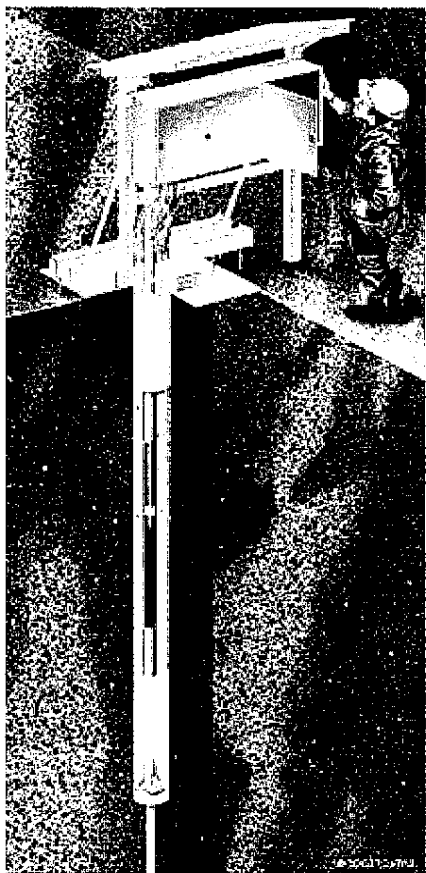
Studies using the thermal FEM model for the Prototype Repository including the rock, backfill, buffer and the six canisters have been reported /Kristensson and Hökmark 2007/. A report concerning 1 D THM modelling of the buffer in deposition hole 1 and 3 will soon be published after internal review of Clay Technology. A report concerning a

3D THM model of the entire experiment is in progress. In this report the possibility of spalling is investigated and also the stress state on a thought fracture plan is studied. The THM modelling of the Prototype Repository according to the initial planning has been delayed.

The analyses of the samples of gas and water from the buffer and backfill continue.

A new project plan which includes the excavation of the outer section of the Prototype Repository has been approved. According to the time table for the project the excavation will start at the beginning of 2011. The planning of this work has started.

### 4.3 Long Term Test of Buffer Material



*Schematic drawing of a test parcel.*

The project Long Term Test of Buffer Material (Lot) aims to validate models and hypotheses concerning mineralogy and physical properties in a bentonite buffer.

Seven test parcels containing heater, central tube, clay buffer, instruments and parameter controlling equipment have been placed in boreholes with a diameter of 300 mm and a depth of around 4 m.

Temperature, total pressure, water pressure and water content, are measured during the heating period. At termination of the tests, the parcels are extracted by overlapping core-drilling outside the original borehole. The water distribution in the clay is determined and subsequent well-defined mineralogical analyses and physical testing of the buffer material are made.

The test parcels are also used to study other processes in bentonite such as cation diffusion, microbiology, copper corrosion and gas transport under conditions similar to those expected in a KBS-3 repository.

## Achievements

All the field equipment has been working well and data from the three ongoing test parcels have been collected and controlled, see Table 4-1. Additional mineralogical analyses have been performed on the A2 parcel material in order to improve the involved processes. Further analyses are planned and the reporting of these will be made separately from the main report concerning the A2 test.

The report concerning the A2 test has been published and the A0 report is on review. Reporting of the experimental studies on diffusive transport of ions in bentonite is ongoing and is planned to be published in scientific journals.

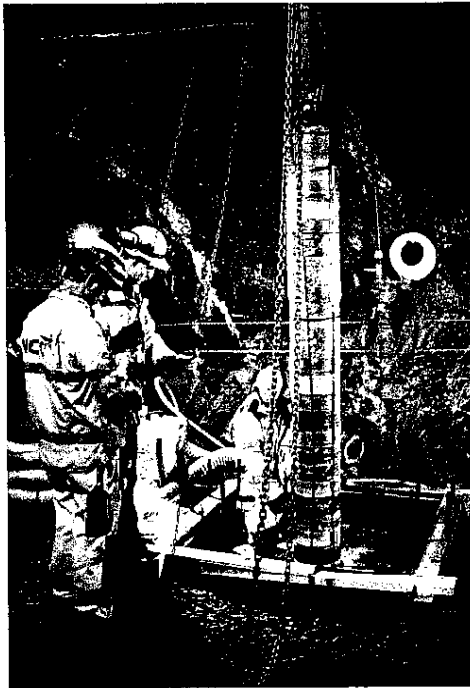
**Table 4-1 Buffer material test series.**

Type	No.	max T	Controlled parameter	Time (years)	Remark
A	1	130	T, [K <sup>+</sup> ], pH, am	1	Reported
A	0	120-150	T, [K <sup>+</sup> ], pH, am	1	Reported
A	2	120-150	T, [K <sup>+</sup> ], pH, am	5	Reported
A	3	120-150	T	>>5	Ongoing
S	1	90	T	1	Reported
S	2	90	T	>5	Ongoing
S	3	90	T	>>5	Ongoing

A = adverse conditions, S = standard conditions, T = temperature, [K<sup>+</sup>] = potassium concentration, pH = high pH from cement, am = accessory minerals added

An oral presentation of the modelling of the LOT A2-parcel was given by David Arcos, Amphos21, at the '4<sup>th</sup> meeting on Clays in Natural & Engineered Barriers for Radioactive Waste Confinement' in Nantes. At the same conference a poster presentation was given by Clay Technology concerning effective diffusion coefficients in compacted bentonite.

## 4.4 Alternative Buffer Materials



*Installation of one of the three test parcels. The photo illustrates the mixing of different compacted buffer blocks.*

In the Alternative Buffer Material test, ABM, eleven buffer materials with different amount of swelling clay minerals, smectite counter ions and various accessory minerals are tested.

The test is performed in the rock at repository conditions except for the scale and the adverse conditions (the target temperature is set to 130°C). Three parcels containing heater, central tube, pre-compacted clay, buffer, instruments and parameter controlling equipment have been emplaced in vertical boreholes with a diameter of 300 mm and a depth of 3 m. Parallel to the field tests, laboratory analyses of the reference materials are going on.

The project is carried out using materials that are possible as future buffer candidate materials. The main objectives are to:

- Compare different buffer materials concerning mineral stability and physical properties, both in laboratory tests of the reference materials but also after exposure in field tests.
- Study the interaction between metallic iron and bentonite. This is possible since the central heaters are placed in tubes made of straight carbon steel.

### **Achievements**

The work with analyses of material from test package 1 (retrieved in May 2009) has continued during the first four month of 2010. The analyses financed by SKB are focusing on three materials: MX-80, Deponit CAN and Asha 505.

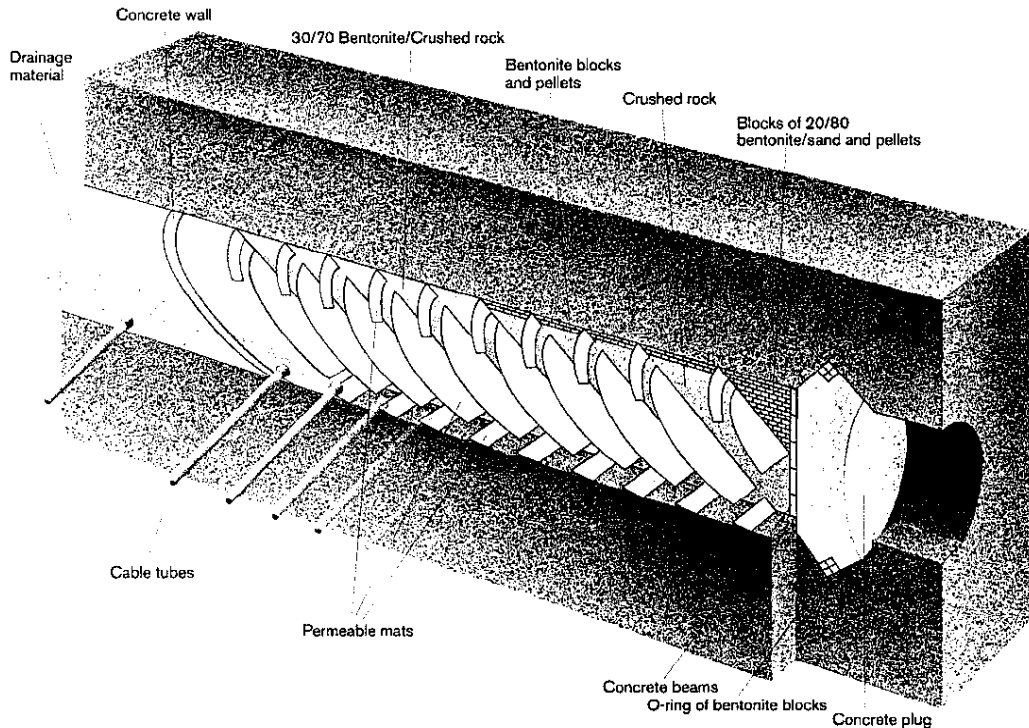
The results from the laboratory analyses show that the degree of saturation was high in all positions of the test package (water content and density were determined in all blocks). Swelling pressure and hydraulic conductivity have been determined in the positions closest to the heater and closest to the rock for the three materials of main interest. A decrease in swelling pressure could be determined for the heated material compared to the reference samples, especially for the Asha 505 material.

Data from the two test packages running have been collected and controlled during the period. A report, including results from the work with characterisation of the reference materials, the work with termination of test package 1 and also results from analyses of the test material is under preparation and will be finished during the summer of 2010.

Two oral presentations regarding the ABM project were made at the clay conference in Nantes in March 2010:

- Patrik Sellin, SKB, gave some background to the project and also presented some new laboratory results from BGR. An interesting result was that the initial very different cation distribution for the different bentonite blocks seemed to homogenise to similar distribution at the end of the experiment, indicating vertical transport between adjacent blocks.
- Daniel Svensson, SKB, presented results from iron–bentonite measurements performed at MAX-Lab in Lund using X-ray Absorption Near Edge Structure (XANES) spectroscopy.

## 4.5 Backfill and Plug Test



The Backfill and Plug Test includes tests of backfill materials, emplacement methods and a full-scale plug. The inner part of the tunnel is filled with a mixture of bentonite and crushed rock (30/70) and the outer part is filled with crushed rock and bentonite blocks and pellets at the roof.

The integrated function of the backfill material and the near-field rock in a deposition tunnel excavated by blasting is studied as well as the hydraulic and mechanical functions of the full-scale concrete plug.

The entire test set-up with backfill, instrumentation and casting of the plug was finished in the end of September 1999 and the wetting of the 30/70 mixture through filter mats started in late 1999. The backfill was completely water saturated in 2003 and flow testing for measurement of the hydraulic conductivity was running between 2003 and 2006.

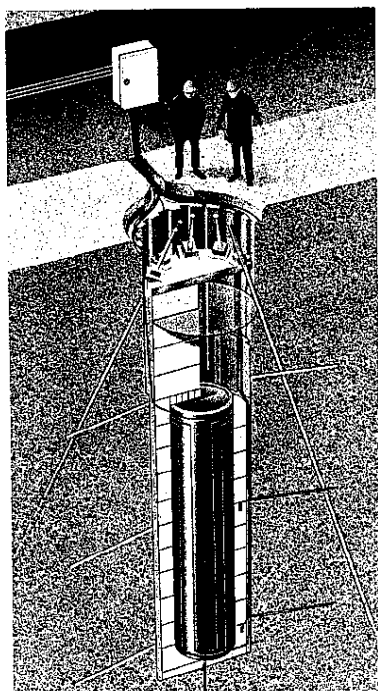
The monitoring comprise continuous measurements and registrations of water pressure and total pressure in the backfill and water pressure in the surrounding rock as well as leakage of water through the plug.

### **Achievements**

The main work has included continuous measurements and registrations of water pressure and total pressure in the backfill and water pressure in the surrounding rock as well as leakage of water through the plug. Some leaking couplings have been taken care of.

Measurement of local hydraulic conductivity in the zone with crushed rock through installed equipments ("CT-tubes") is continuing but delayed.

## 4.6 Canister Retrieval Test



The Canister Retrieval Test is aiming at demonstrating the readiness for recovering of emplaced canisters also after the time when the bentonite is fully saturated.

In the Canister Retrieval Test two full-scale deposition holes have been drilled, at the -420 m level, for the purpose of testing technology for retrieval of canisters after the buffer has become saturated.

These holes have been used for studies of the drilling process and the rock mechanical consequences of drilling the holes.

Canister and bentonite blocks were emplaced in one of the holes in 2000 and the hole was sealed with a plug, heater turned on and artificial water supply to saturate the buffer started.

In January 2006 the retrieval phase was initiated and the canister was successfully retrieved in May 2006. The saturation phase had, at that time, been running for more than five years with continuous measurements of the wetting process, temperature, stresses and strains.

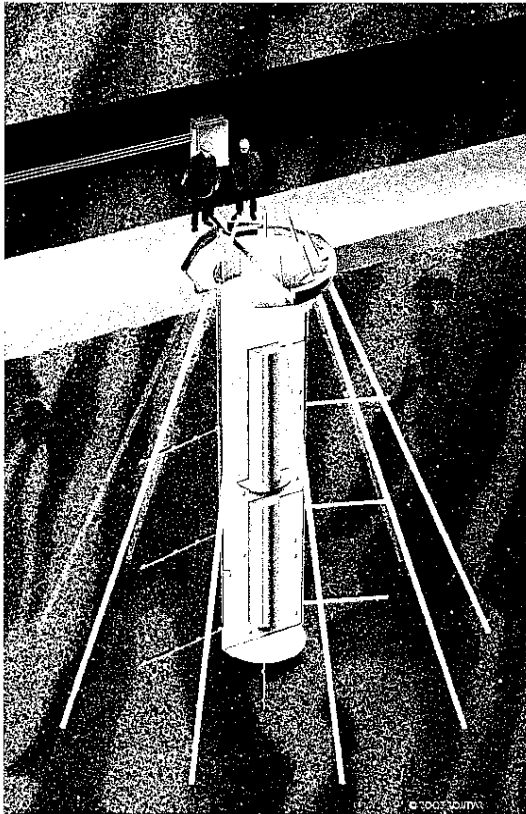
### **Achievements**

The laboratory work has produced data concerning the mechanical character, the swelling pressure/hydraulic conductivity and the chemical/mineralogical constitution. The reporting of the findings is in progress both in form of a SKB-report and an article. The article is intended to be presented in a scientific journal to make the findings of the buffer analyses public.

In the Task Force on Engineered Barrier Systems (EBS-Task Force) one of the full scale assignments (assignment 2.2) concerns modelling the Canister Retrieval Test (CRT). Several teams have presented results within this assignment.

Work concerning modelling of the natural homogenization process in the CRT experiment was presented in the conference "Clays in Natural & Engineered Barriers for Radioactive Waste Confinement" (Nantes, 29<sup>th</sup> March – 1<sup>st</sup> April, 2010). A manuscript has also been submitted for review.

## 4.7 Temperature Buffer Test



The French organisation Andra carries out the Temperature Buffer Test (TBT) at Äspö HRL in co-operation with SKB. The aims of the TBT are to evaluate the benefits of extending the current understanding of the THM behaviour of engineered barriers during the water saturation transient to include high temperatures, above 100°C.

The scientific background to the project relies on results from large-scale field tests on engineered barrier systems, notably Canister Retrieval Test, Prototype Repository and Febex (Grimsel Test Site).

The test is located in the same test area as the Canister Retrieval Test, which is in the main test area at the -420 m level. The experiment includes two heaters in the axis of the deposition hole, one on top of the other, separated by a compacted bentonite block. The heaters are 3 m long and 610 mm in diameter and are constructed in carbon steel. Each one simulates a different type of confinement system: a bentonite buffer only (bottom section) and a bentonite buffer with inner sand shield (upper section). An artificial water pressure is applied in a slot between the buffer and rock, which is filled with sand and functions as a filter.

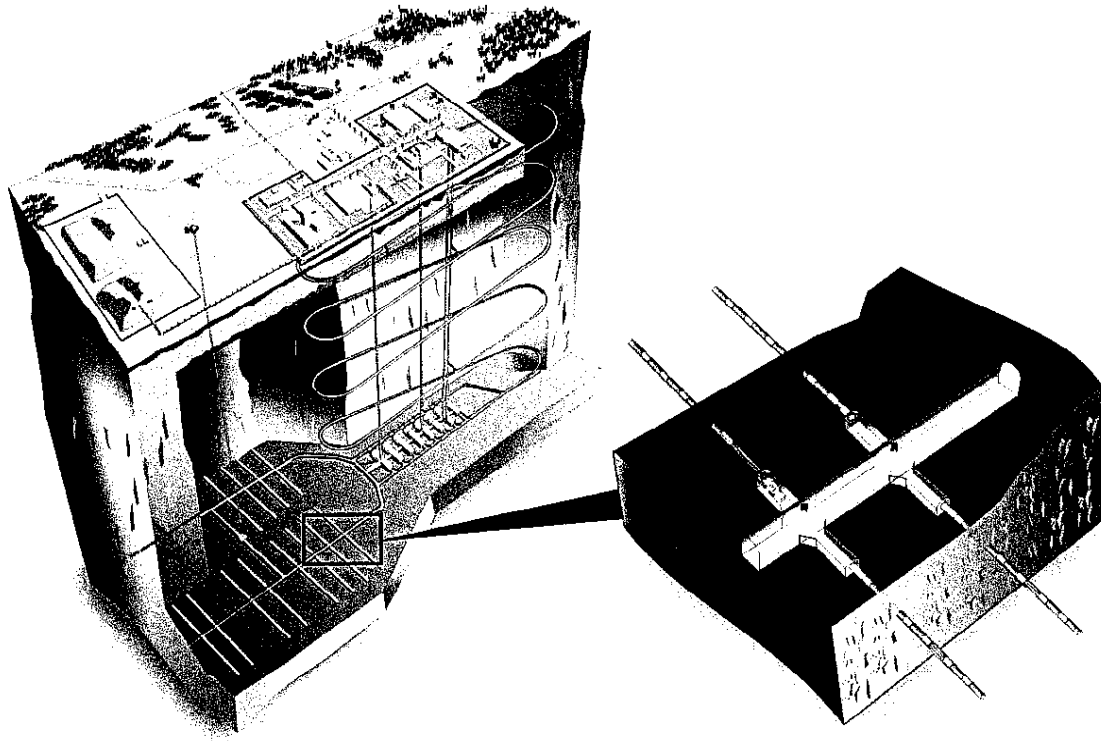
Data acquisition is continuously ongoing and data is transferred by a link from Äspö to Andra's head office in Paris.

### ***Achievements***

The TBT experiment has now been dismantled. A number of activities were performed during the period from January to April 2010: the middle cylinder (C2) and the lower rings (R1/R6) were sampled and removed, the lower heater was removed, and finally the lower cylinder (C1) was sampled and removed.

A large number of cores have been taken for determination of water content and density. These analyses have been performed concurrently with the dismantling operation. Several large pieces have been collected for hydro-mechanical and chemical characterisations, and several sensors have been collected for function control. Two big undisturbed interface samples with bentonite and iron have been taken, one on top of the lower heater, and one on the lower end of the vertical side of the heater. Four cores with undisturbed interface samples with bentonite/concrete were taken from cylinder 1 and the bottom plate.

## 4.8 KBS-3 Method with Horizontal Emplacement



The possibility to modify the reference KBS-3 method and make serial deposition of canisters in long horizontal deposition holes (KBS-3H), instead of deposition of single canisters in vertical deposition holes (KBS-3V), is studied in this project.

One reason for proposing the change is that the deposition tunnels in KBS-3V are not needed if the canisters are disposed in long horizontal deposition holes and the excavated rock volume and the amount of backfill can be considerably reduced. This in turn reduces the environmental impact during the construction of the repository and also the construction costs.

The site for the demonstration of the method is located at -220 m level. A niche with a height of about 8 m and a bottom area of 25×15 m forms the work area.

Two horizontal deposition holes have been excavated, one short with a length of about 15 m and one long with a length of about 95 m. The deposition equipment is being tested in the long hole and the short hole will be used for testing of different drift components.

The project is a joint project between SKB and Posiva. The current phase of the project; "Complementary studies of horizontal emplacement KBS-3H" is ongoing. The main goal of the complementary studies (2008-2010) is to develop the KBS-3H solution to such a state that the decision on full-scale testing and demonstration can be made.

### **Achievements**

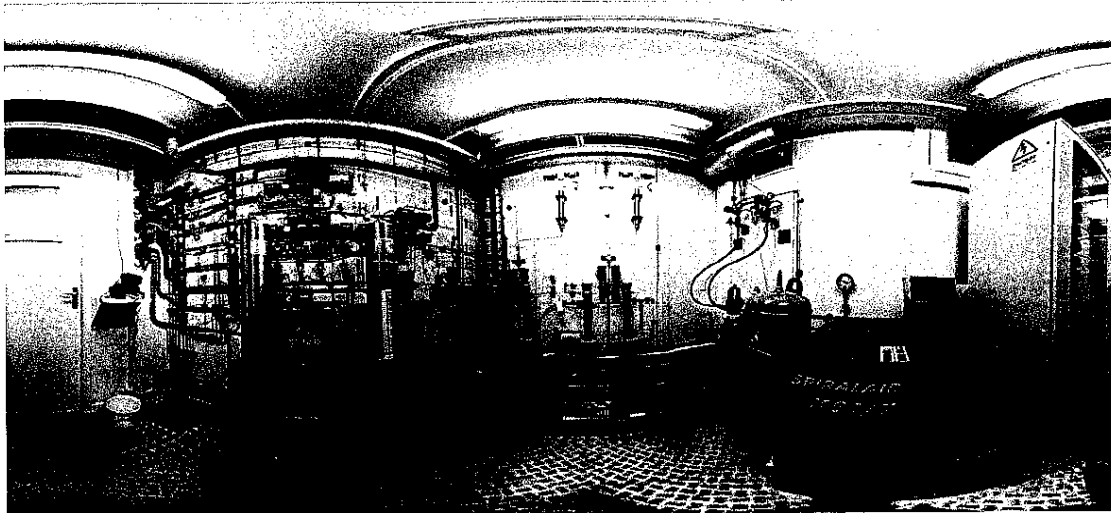
In the beginning of 2010 the void behind the compartment plug was filled with bentonite pellets as preparation for the third test. Results from the second test show that the grouting have had significant effect and lowered the leakage through the casting to almost zero. The following third test will verify the ability to blow pellets behind the compartment plug and to pump in water with correct speeds. There is also a big interest in monitoring the effect of the pellets on the water leakage into the rock volume. Preliminary results indicate a reduction of the leakages into the rock. The leakage through the casting has however been somewhat fluctuating during the third test.

Leakage levels are still low and the plug fulfils the test criteria. At the later part of the test the leakage was reduced to almost zero and remained stable.

It has been decided to extend the compartment plug test and run a six month test in order to monitor the plug behaviour during a longer time period. The six month test will be completed at the end of September 2010.

The planning of the sub system test phase 2011 to 2014 has continued and the work follows the schedule. The completed project plan will be presented at the end of the current project phase. Input to the planning by Posiva and SKB will be in May and September 2010. The next phase of the project has also been incorporated in the LUCOEX EU application.

## 4.9 Large Scale Gas Injection Test



Panorama of the laboratory of the Large Scale Gas Injection Test (Lasgit) at -420 m level in Äspö HRL.

Current knowledge pertaining to the movement of gas in a compacted bentonite buffer is based on small-scale laboratory studies. These diagnostic tests are designed to address specific issues relating to gas migration and its long-term effect on the hydro-mechanical performance of the buffer clay.

Laboratory studies have been used to develop process models to assess the likely implications of gas flow in a hard-rock repository system. While significant improvements in our understanding of the gas-buffer system have taken place, a number of important uncertainties remain. Central to these is the issue of scale and its effect on the mechanisms and process governing gas flow in compact bentonite.

The question of scale-dependency in both hydration and gas phases of the test history are key issues in the development and validation of process models aimed at repository performance assessment. To address these issues, a Large Scale Gas Injection Test (Lasgit) has been initiated.

Its objectives are:

- Perform and interpret a large scale gas injection test based on the KBS-3V design concept.
- Examine issues relating to up-scaling and its effect on gas migration and buffer performance.
- Provide information on the process of hydration and gas migration.
- Provide high-quality test data to test/validate modelling approaches.

In February 2005 the deposition hole was closed and the hydration of the buffer initiated. During 2007 preliminary hydraulic and gas transport tests were performed. These were repeated in 2009, giving information on the maturation of the buffer in order to examine the temporal evolution of these properties. When the buffer is fully-hydrated a comprehensive series of gas injection tests will be undertaken to examine the mechanisms governing gas flow in bentonite.

### **Achievements**

The first four month of 2010 involved the continuation of the gas testing that was started on the 28<sup>th</sup> of May 2009 (day 1577). As in previous gas tests, filter FL903 located in the lower filter array of the canister was selected. Neon was selected as the gas permeant in order to allow monitoring of the leakage to the host rock.

**Figure 4-2** shows the evolution of injection gas pressure and flow into the clay and is a continuation of the results reported for the last four month of 2009. As seen, the system continually over- and under-shoots as the pressure changes with time, something that has been observed previously for laboratory experiments.

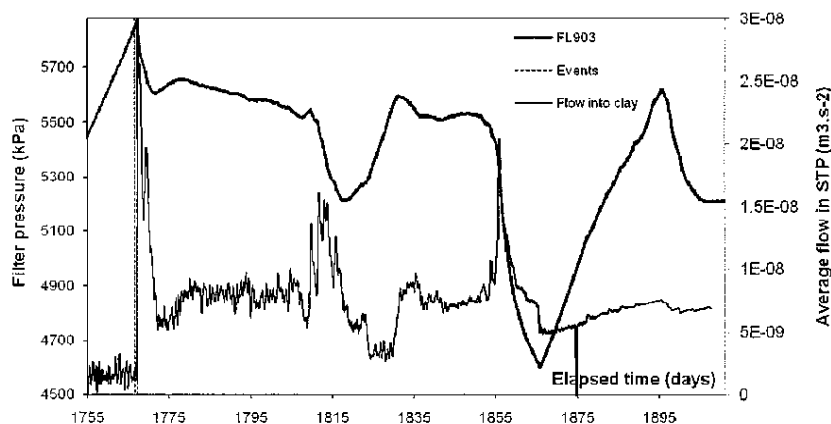
At approximately day 1810, the flow into the clay increased for a second time, resulting in a drop of pressure in filter FL903 of about 300 kPa. Gas flow was reduced and pressure in FL903 slowly increased once more to return to approximately 5,600 kPa by day 1830, where once again pressure slowly decreased to 5,520 kPa (over- and under-shooting).

Gas flow into the clay increased for a third time, with a major flux pulse on day 1853. This resulted in a considerable loss of filter pressure, which was aided by a leaking valve on the injection pump. On day 1864 the valve was closed fully and the pressure in FL903 began to rise. While this event was not planned, it was effectively a pressure shut-in test and gave the opportunity to observe whether a gas peak similar to the gas breakthrough on day 1767 of 5,872 kPa would occur. As seen, the gas pressure peaked at approximately 5,600 kPa and did not correspond with a significant peak in flow into the clay. Following the peak, gas pressure reached an asymptote of 5,210 kPa.

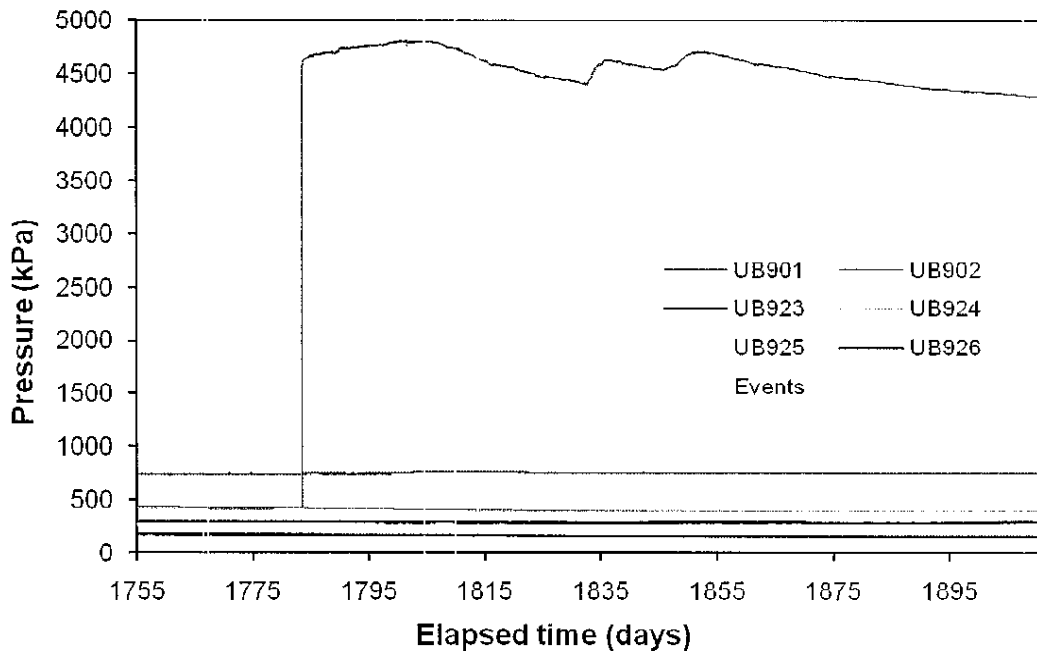
**Figure 4-3** shows the results given by the pore-pressure sensors within the bentonite buffer. As can be seen, sensor UB902 greatly increased on day 1783 from 420 kPa to 4,590 kPa. The response of the sensor thereafter coincides with the observations of the gas pressure and flow in the injection filter FL903.

The decision was taken to stop gas injection on day 1907 (25<sup>th</sup> April 2010) and the system is now undergoing a gas shut-in phase. The results of this will become clearer in the second third of the year.

The highly instrumented Lasgit experiment has shown that gas has propagated within the deposition hole. Significant pressure changes have been observed in several of the pressure and stress sensors, giving insight into the direction and propagation of the gas, as well as the hydromechanical response of the buffer system. As with the previous gas test in 2007, propagation has been in a downward direction. However, the extended period of gas injection post-breakthrough has shown that gas continues to move around the system and has propagated to a number of locations.

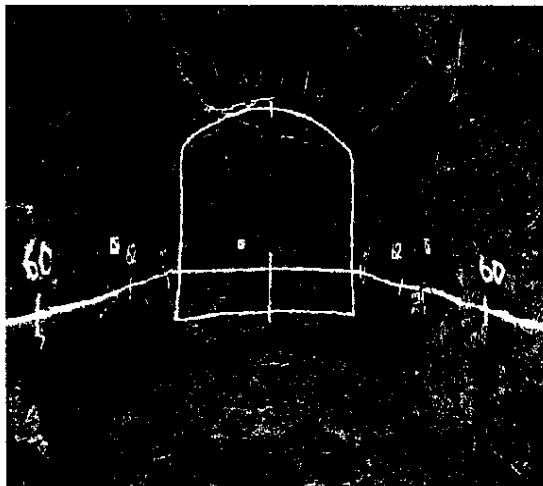


**Figure 4-2** The evolution of the injection gas pressure and the flow into the clay. The two black event lines represent the start of gas flow into the clay at 5,833 kPa and the maximum gas pressure experienced (5,872 kPa).



**Figure 4-3** The pore-pressure response of the sensors located within the bentonite buffer. As can be clearly seen, sensor UB902 greatly increased on day 1783 from 420 kPa to 4,590 kPa. The response of the sensor thereafter coincides with the observations of the gas pressure and flow in the injection filter FL903.

#### 4.10 Sealing of Tunnel at Great Depth



The Tass-tunnel in Äspö HRL.

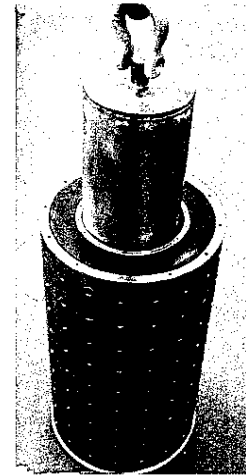
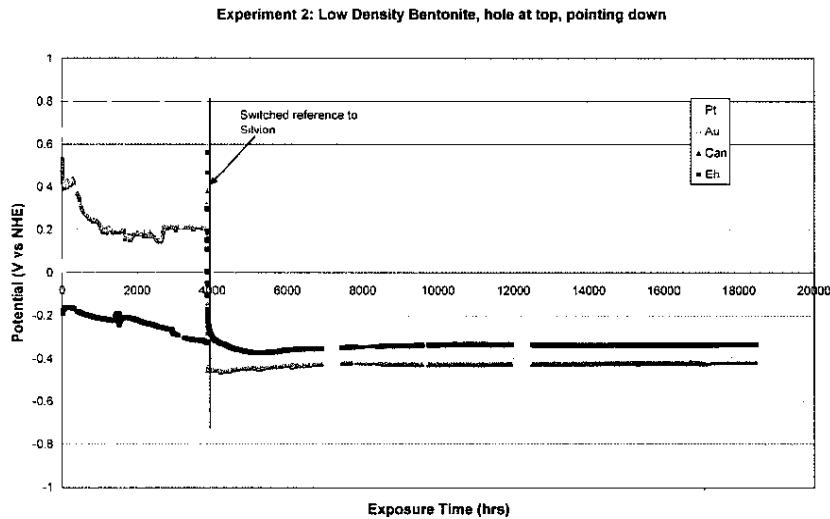
Although the repository facility will be located in rock mass of good quality with mostly relatively low fracturing, sealing by means of rock grouting will be necessary. Ordinary grouts based on cement cannot penetrate very fine fractures and due to long term safety reasons a sealing agent that produces a leachate with a pH below 11 is preferred. In the sealing project at Äspö HRL a cement-based low-pH grout and a solution grout consisting of silica sol are used and evaluated. Newly developed understanding and design methods are taken into use and evaluated.

Another issue for the planned repository is the contour and status of the remaining rock after blasting. Drilling and blasting are given special attention and subsequent adjustments aim at successive improvements.

#### Achievements

The field works within the project are completed and measurements of leakage into the tunnel are the only ongoing work in field. Reports are now being written and are planned to be completed during 2010.

## 4.11 In Situ Corrosion Testing of Miniature Canisters



Example of electrochemical potential data obtained from one miniature canister with experiment.

Miniature canister with support cage.

The MiniCan project is designed to provide information about how the environment inside a copper canister containing a cast iron insert would evolve if failure of the outer copper shell were to occur. The development of the subsequent corrosion in the gap between the copper shell and the cast iron insert would affect the rate of radionuclide release from the canister. The information obtained from the experiments will be valuable in providing a better understanding of the corrosion processes inside a failed canister.

Miniature canisters with a diameter of 14.5 cm and containing 1 mm diameter defects in the outer copper shell have been set up in five boreholes.

The boreholes have a diameter of 30 cm and a length of 5 m. All five canisters were installed in the beginning of 2007 in Äspö HRL.

The canisters are mounted in support cages, four of which contain bentonite (three low density bentonite, one compact bentonite), and are exposed to natural reducing groundwater. Together with corrosion test coupons which are also in the boreholes, the canisters will be monitored for several years. The corrosion will take place under realistic oxygen-free conditions that are very difficult to reproduce and maintain for long periods of time in the laboratory.

### Achievements

During the reporting period, automated monitoring of the miniature canister experiments has continued. Data are being collected for the corrosion rate of copper and iron electrodes, and electrochemical potentials are being recorded for a range of electrodes, including Eh, gold, platinum, iron and copper. In addition, strain gauge data are being collected for two of the canisters. Data analysis has been performed and interpretation has been carried out where possible. The electrochemically measured corrosion rates for both iron and copper are higher than expected (using the LPR and AC impedance techniques), but it is not clear whether these are the results of experimental artefacts. The corrosion rates will be confirmed by dismantling one of the experiments and carefully analysing the material removed.

Planning for the removal of experiment 3 is in progress. Preparation of the equipment required for removal and analysis of experiment 3 will take place during 2010 with the aim of removing it from the borehole in early 2011. During 2010, a further round of water analyses will be carried out on samples removed from the vicinity of the corrosion experiments.

A report on the set up of the experiments and the results obtained up to May 2008 has been printed as a SKB report /Smart and Rance 2009/. In addition, two progress reports have been produced /Smart et al. 2009, 2010/.

## 4.12 Cleaning and Sealing of Investigation Boreholes



*Installation of a copper plug in a 200 mm borehole.*

The objective of the project is to work out a concept for rinsing, stabilising and plugging of deep boreholes drilled from the surface and repository level, such as they do not form significant transport paths for radionuclides from the repository to the biosphere. The project was initiated 2002 and Phase 1 to 3 have been finalised.

The Phase 4 of the project comprises the following sub-projects:

1. Characterisation and planning of borehole sealing
2. Quality assessment and detailed design
3. Sealing of two 300 mm underground boreholes
4. Interaction of clay and concrete plugs at 220 m depth

### **Achievements**

During the period, the sub-projects 3 and 4 of the 4<sup>th</sup> Phase of the project dealing with Cleaning and Sealing of Investigation Boreholes have been in focus with special respect to the practical performance of dense clay plugs and to the interaction of contacting clay and concrete of CBI type. Both activities have demonstrated that the techniques proposed for sealing deep boreholes and boreholes extending from a repository work are feasible.

### **Sealing of two 300 mm underground boreholes at Äspö HRL**

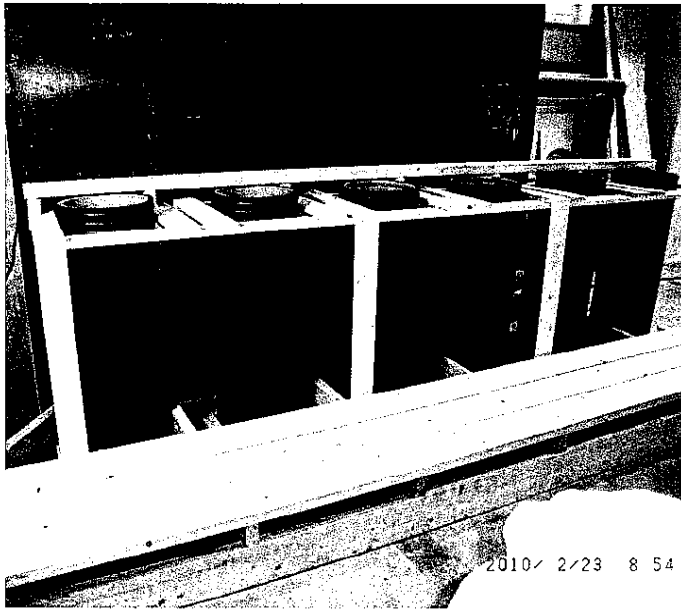
The possibility to seal large-diameter boreholes with significant inflow of water (up to 30 l/min) was investigated by plugging two boreholes, about 20 m long and 300 mm in diameter, at Section 2950 in the Äspö ramp. On-site casting of concrete was used where the inflow of water was highest and precompacted dense blocks of smectite-rich clay were installed where the rock was “dry”. The finally matured clay plugs will have a density of approximately 2000 kg/m<sup>3</sup> and a hydraulic conductivity of less than 10<sup>-12</sup> m/s, which is estimated to be more than one order of magnitude lower than the bulk conductivity of the surrounding rock. The plugging campaign was successful and could be pursued in a few days as planned.

### **Interaction of clay and concrete plugs at 220 m depth**

The matter of chemical interaction of a plug consisting of CBI concrete in contact with smectite-rich seals was investigated by extracting a rock column with a 5 m deep plugged borehole with 80 mm diameter at 220 m depth at Äspö. It had been on site for 3 years and was expected to have become fully water saturated and matured. The piece of rock was released by slot drilling and sectioning by wire sawing to give a number of 100 mm thick discs from the concrete/clay contact zone as well as from different distances from this zone. A comprehensive program for investigating the concrete and clay by chemical analyses, scanning microscopy and XRD, as well as by determining ordinary physical properties like swelling pressure and hydraulic conductivity, was followed. Complete laboratory recordings will be obtained before summer this year but preliminary results are already at hand. The results show that neither the concrete nor the clay had undergone substantial degradation in the 3 year testing time. However, chemical reactions have taken place and thereby caused changes in physical behaviour of the plug components, particularly in the clay. The rate of degradation is not yet known. Repeating the study by carrying out the corresponding investigation of a "twin" hole at the same level in 5 years from now would shed further light of the degrading mechanisms and lead to safer prediction of the rate of chemically induced alterations. However, it is concluded already at this stage that development of other concrete brands of more inert type is strongly desired.

An important conclusion from the work is that the characteristics of boreholes to be sealed, primarily the diameter and the nature of the fracture zones where concrete seals shall be placed, must be better known than presently available techniques allow for. This is because borehole characteristics determine the net density and homogeneity of clay and concrete plugs. Also, the study has emphasised the need for developing techniques for placing such seals at large depths as well as for preparing the boreholes by cleaning and stabilisation.

## 4.13 Concrete and Clay



*Cylinders used for the experiments (left) and deposition of cylinder in a selected site (right).*

The main focus of the project Concrete and Clay is on studies of the long term evolution of cementitious materials in host rock, its interactions with the host rock and embedded waste materials as well as with bentonite. During 2010 - 2012 a total of about 15 experiments will be prepared and deposited at different sites in the Äspö tunnel.

The project is expected to run for up to 30 years but according to present plans the first experiments will be over-cored and retrieved already after 3 years. Experiments will then be retrieved at regular intervals and only a few will be left for the entire 30 year period.

### **Achievements**

During the first four month of 2010, experiments focusing on the degradation of different waste forms in contact with concrete have been prepared and deposited in holes in the tunnel floor. In these experiments both metallic and organic waste forms have been included and in total 4 different metals and 4 different types of organic waste forms were used. The experiments were prepared ex situ in the shape of one meter long cylinders with a diameter of 300 mm, which after curing were deposited on the selected site. The different waste forms were separated by about 250 mm in the concrete matrix in order to minimise the interactions between them as much as possible.

During the autumn of 2010 the final planning of the experiments included in second stage (of three) of this project will be finalised. The most important tasks will be to (a) chose which experiments to be implemented, (b) specify the exact details of each experiment, (c) prepare and characterise the sites for the different experiments, and (d) prepare the working plans.

## 4.14 Low-pH Programme



*Field test with low-pH shotcrete at Äspö HRL executed within the EC project ESDRED in 2006.*

The purpose of this programme is to develop low-pH cementitious products that can be used in the final repository for spent nuclear fuel. These products would be used for sealing of fractures, grouting of rock bolts, rock support and concrete for plugs for the deposition tunnels.

SKB has for many years had a close co-operation with Posiva (Finland) and Numo (Japan) in this field. The main focus of the low-pH programme during 2008 and 2009 has mainly been on developing formulas for low-pH concrete to be used for construction of the sealing plugs for the deposition tunnels.

### **Achievements**

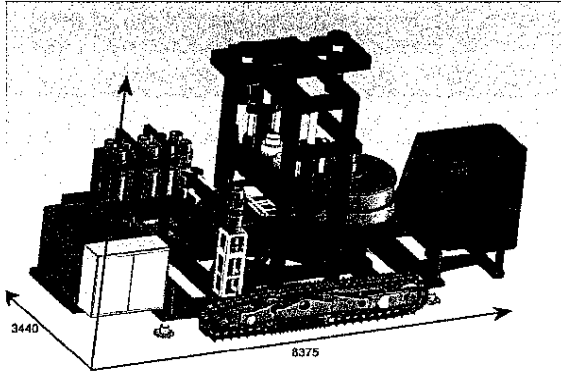
The work during the first four month of 2010 has mainly been limited to follow up the activities from 2009 with the rock bolts and rock support. The design work of the plugs for the deposition tunnel may require additional investigation about material parameters of the low-pH concrete.

The main activity during the reporting period has been the preparation of an official report of the work performed during 2009. The report is expected to be ready at the end of 2010. During the reporting period also the preparation for over coring of the first set of rock bolts has been ongoing, as well as follows up of the corrosion experiments with carbon steel rock bolts in low-pH concrete.

The work within the pH-project has been ongoing during the reporting period and in February pH-measurements had been performed in nine laboratories in six different countries. Analysis of the results has been done during March and April and an interim report was presented mid April.

During the next period “real” samples of low pH-products will be prepared by the members of the consortium. The pH-measurements will be done in the same laboratories as in the previous phase. The preparation of the samples is scheduled for June and the pH-measurements will the take place mid September after 90 days of curing. The analysis of the results and reporting of this phase will be ongoing up to the later part of 2010. The pH-project is expected to be finished early 2011.

## 4.15 Drilling Machine for Deposition Holes



*Artist impression of the drilling machine for deposition holes with preliminary dimensions.*

For the drilling of the deposition holes for the installation of the canisters in the Prototype repository and the Canister Retrieval Test, SKB used a modified TMB machine. In total SKB has been drilling 17 deposition holes at Äspö HRL /Andersson and Johansson 2002/. For the final repository it was decided that new equipment would be needed and a "state of the art" investigation of available technologies was performed during 2006. The conclusion from the investigation was that the push reaming technique would be the method that could meet stringent requirement on the deposition hole and still have high production rate.

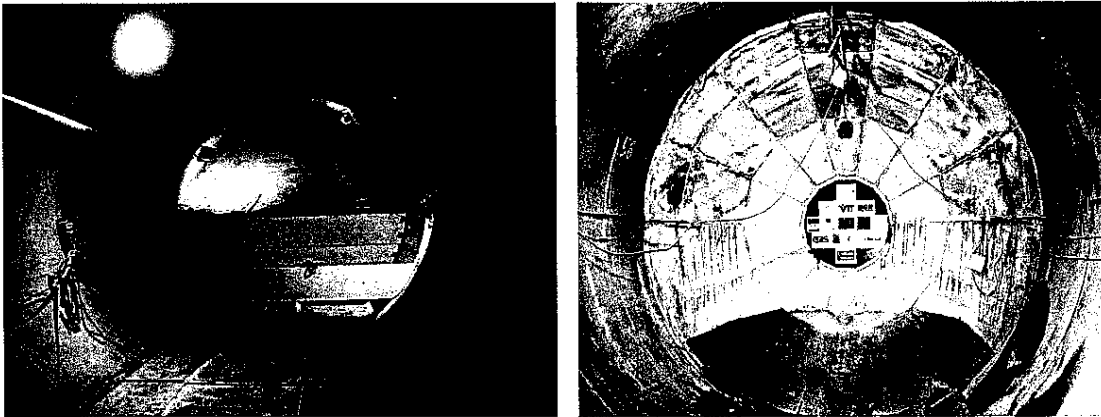
This technology has also been tested in Finland for drilling of three deposition holes in the research tunnel at Olkiluoto /Autio 1997/. The same technology has also been used for the excavation of the two KBS-3H deposition tunnels at -220 m level in Äspö HRL.

### **Achievements**

A feasibility study of a self propelled drilling machine using the push reaming technique has been performed by SKB and the study was completed late 2008. The requirements for the deposition holes are very stringent as well as production rate and costs for the drilling of the deposition holes.

From early 2009, SKB and Posiva have discussed to form a joint project for the continued work with the drilling machine and these discussions are still ongoing and therefore no progress during this period can be reported.

## 4.16 Development of End Plugs for Deposition Tunnels



*The plug installation for section I in the Prototype Repository*

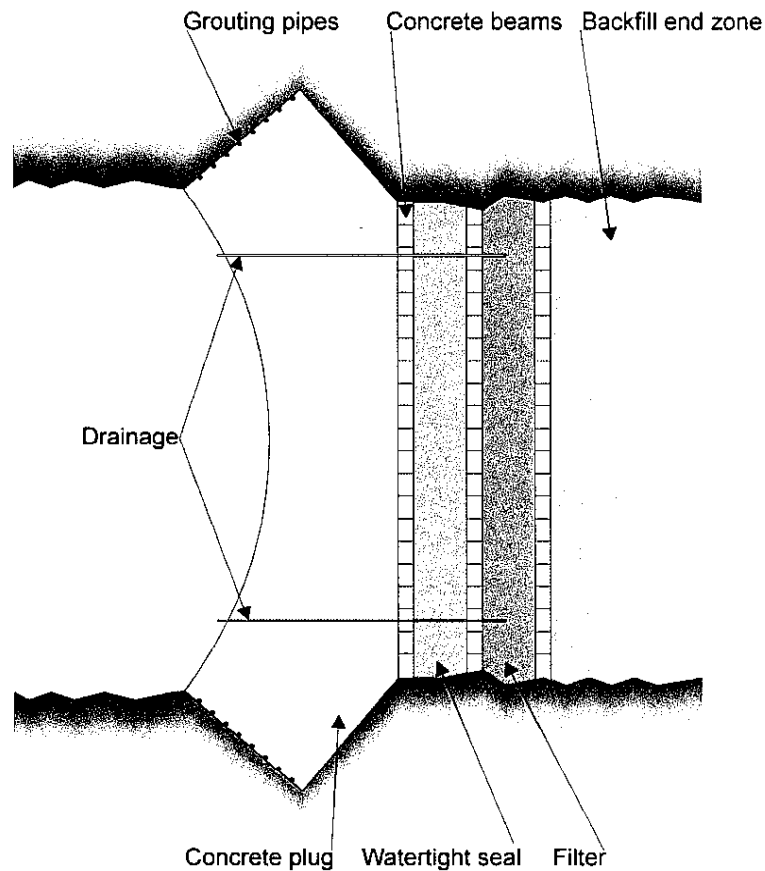
The development of end plugs for deposition tunnels has been an issue for SKB for several years. Two kinds of solutions have been investigated, vault plug and friction plug. To obtain as watertight a plug as possible, the choice for further development has been the vault plug. To improve the water-tightness, the concrete plug has in the reference design been complemented with a watertight seal and a filter, collecting water leaking from the backfilled deposition tunnel during the curing phase.

This principal solution is currently being evaluated and it is the analysed design that constitutes the reference design at this stage of development.

The detailed, as well as the principal solution, will be further developed before the construction of the final repository and deposition of encapsulated spent fuel commences.

### **Achievements**

The limitations and possibilities have since the very beginning of the development of end plugs changed which affects the design and its performance. Two kinds of different solutions have been investigated, vault plug and friction plug. With the goal to achieve as watertight a plug as possible, the project choice for further development was the vault plug seen in Figure 4-4.

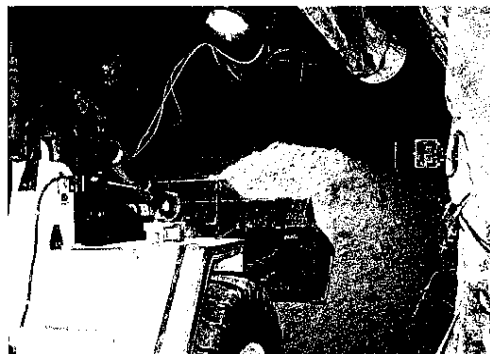
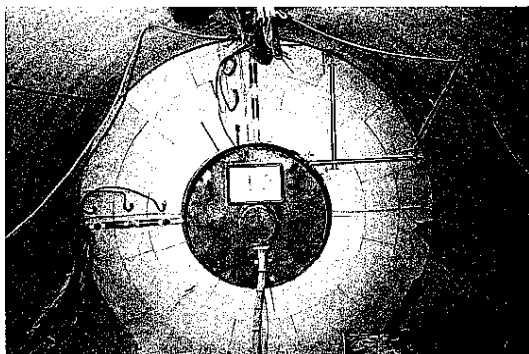


**Figure 4-4** *The reference design for end plugs for deposition tunnels.*

The project is now in phase 3, where construction documents have been compiled along with a description of the method and a control programme. Conditions, demands and function descriptions for the plug were stated during phase 1 of the project. During phase 2, major simulations and analysis regarding strength and cracking was done. In the end of phase 2, an evaluation of the construction between friction and vault plug were made. All important documents and results have been compiled in a decision document for phase 1 and 2 to ensure the traceability of the choices made for the reference design. The document has been reviewed and is now in process to be approved. The results from the performed additional strength simulations with unsymmetrical load show no larger effects.

The results from the project will be published in a SKB R-report, estimated to be published in spring 2011.

## 4.17 Task Force on Engineered Barrier Systems



The Task Force on Engineered Barrier Systems (EBS) is a continuation of the modelling work in the Prototype Repository Project, where also modelling work on other experiments concerning both field and laboratory tests is conducted. The Äspö HRL International Joint Committee has decided that in the first phase of this Task Force (initiated 2004) work should concentrate on:

**Task 1** - THM modelling of processes during water transfer in buffer, backfill and near-field rock. Only crystalline rock is considered initially, although other rock types could be incorporated later.

**Task 2** - Gas migration in saturated buffer.

The objectives of the tasks are to: (a) verify the capability to model THM and gas migration processes in unsaturated as well as saturated

bentonite buffer, (b) refine codes that provide more accurate predictions in relation to the experimental data and (c) develop the codes to 3D standard (long-term objective).

Participating organisations besides SKB are at present Andra (France), BMWi (Germany), CRIEPI (Japan), Nagra (Switzerland), Posiva (Finland), NWMO (Canada) and Rawra (Czech Republic). All together 12-14 modelling teams are participating in the work.

Since the Task Force does not include geochemistry, a decision has been taken by IJC to also start a parallel Task Force that deals with geochemical processes in engineered barriers. The two Task Forces have a common secretariat, but separate chairmen.

### **Achievements**

#### **Task Force THM/Gas**

The work with modelling of the Canister Retrieval Test at Äspö HRL has continued during this four-month period. Altogether 8 modelling teams are modelling this benchmark.

The task to model the Canister Retrieval Test is divided into two parts where the first part is to model the thermo-hydro-mechanical behaviour of a central section of the test-hole with given boundary conditions. The second task is to model the entire test. Most teams have finished their calculations. Five of the teams have modelled the entire test, while the other three have only modelled the central section. Reports of these results were requested before the end of March.

Four suggestions of modelling tasks in the next phase have been presented. Further preparation of these tasks has been made during spring 2010.

**Sensitivity analyses** - This task that implies sensitivity analyses with simple models. The purpose is to provide better understanding of the relationship between simulation variables and performance results regarding: (a) understanding of coupled processes active in the field, (b) identification of relevant key coupled processes, (c) identification of key parameters and (d) effects of parameter uncertainty on results.

**Task 8: hydraulic interaction rock/bentonite** -This task focuses on the hydraulic interaction between the rock and the bentonite and is a joint task with the hydrogeology group. The main project goals are:

- Scientific understanding of the exchange of water across the bentonite-rock interface
- Better predictions of the wetting of the bentonite buffer
- Better characterisation methods of the canister boreholes

The task is related to and concerns modelling of a planned Äspö test in a project called Brie (Buffer-rock interaction experiment). Preparations for this task have been ongoing both during 2009 and the first part of 2010.

**Homogenisation** - This is a task related to erosion and subsequent homogenisation but can also refer to homogenisation in general. The general understanding of bentonite is that it has excellent swelling properties but the homogenisation is not complete due to friction, hysteresis effects and anisotropic stress distributions. The task is proposed to involve two phases. In the first phase a number of simple laboratory tests that have been made will be modelled and used for checking and calibrating the mechanical model. In the next phase one or two laboratory tests that simulate bentonite lost in a deposition hole will be performed and preceded by predictive modelling.

**Prototype Repository** - This task is to model one of the two outer deposition holes in the Prototype Repository in Äspö HRL. The motivations for this task are: (a) identical geometry with CRT but natural hydraulic interaction with the rock, (b) extensive instrumentation, (c) interaction buffer/backfill, (d) the test will be excavated just in time to be included in the next phase, (e) it is partly a true prediction and (f) it can be a joint task with the Task Force on Modelling of Groundwater and Solutes.

### **Task Force Geochemistry**

At the beginning of 2010, the work within the chemistry part of the Task Force has been focused on producing a final report on the activities during the first phase of the Task Force (2006 -2009). A joint report will be produced including contribution from all members of the chemistry task force. Among the topics were (a) Presentation of the laboratory work underlying the different benchmark cases (chloride diffusivity, gypsum dissolution and Na/Ca ion exchange with pressure response, core infiltration test), (b) calculations of the benchmark cases, (c) contributions regarding bentonite structure (multi-porosity- and single-porosity-views) and (d) Molecular Dynamics simulations of montmorillonite.

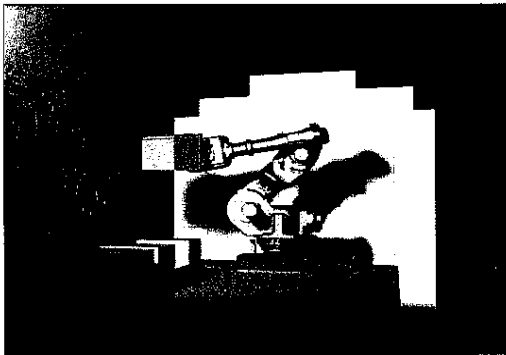
An “intermediate” workshop is being planned involving Carl Steefel, the creator of the reactive transport code CRUNCHFLOW. This workshop will include both hands-on work on the newly implemented multi-porosity features of CRUNCHFLOW as well as discussion on ion equilibrium effects and coupling to swelling pressure.

## 5 Mechanical- and system engineering

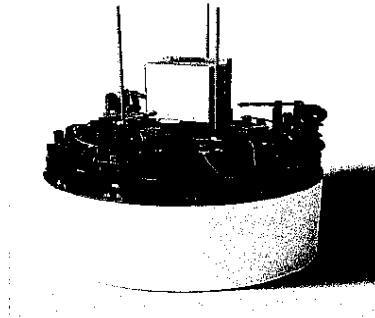
### 5.1 General

At Äspö HRL and the Canister Laboratory in Oskarshamn, technologies for the final disposal of spent nuclear fuel are being developed. Established as well as new technology will be used in the final repository. When it comes to mechanical- and system engineering, well known standard objects with secured function will be used to the fullest possible extent. With standard equipment as a basis, needed adjustments, modifications and adaptations can be made for the intended function. Where no standard objects are available, new technical development will be necessary.

### 5.2 Technical development at Äspö HRL



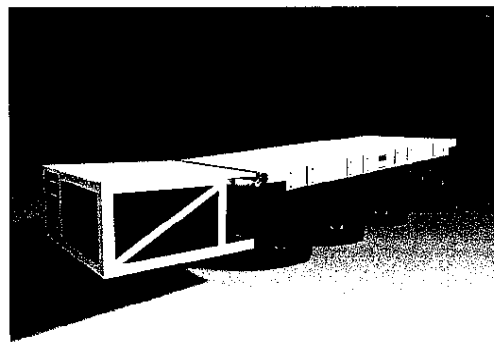
*Backfilling equipment*



*Lifting tool for buffer emplacement*



*Deposition machine*



*Multi purpose vehicle*

The technical systems, machines and vehicles that need to be developed for the future final repository have been identified by an inventory project and preliminary plans made about when each machine should be developed. A total of 175 different products and components known today are to be developed. The number of objects and affiliated information is due to change since the specifications are working documents.

The project started with a pre-study and a concept study, to determine when the production of machines must begin and when they should be completed, as well as deciding whether production of a prototype is necessary. The development of a model for costs has been included in the work. Several projects within mechanical- and system engineering are ongoing and the activities in some of the different projects are described in the text below.

### ***Equipment for backfilling***

This project is studying the machines that will be needed to place the backfill blocks in position at a speed of approximately 240 ton/day. The conclusion from simulations of different robots, which were carried out in 2009, is that robot-technology is able to meet the demands made by the high speed of backfilling (6 m of tunnel in 8 hours). The continuation of the work includes further studies of the robots with tests and model-validation, as well as development of tools and a vision system. Further investigations will be made into a movable platform for robots and the pellets bed in the tunnel. Tests will be carried out both above and below ground.

### ***Buffer emplacement***

This project is investigating whether or not the buffer, in the shape of blocks and rings, can be placed in the deposition holes with the required degree of precision.

The project is working in phase four according to a simplified step-by-step description produced from the operating instructions, which is the document that describes how the placement of bentonite rings will be carried out. The steering gear of the emplacement tool was also completed during the first four month period of 2010. The tool uses vacuum to lift the bentonite rings and is functioning well, however, the buffer rings used for testing were too porous and were easily breaking. Vacuum can hence not be achieved on damaged rings. New buffer rings will be ordered during the second four month period of 2010.

### ***Ramp vehicle***

During the period 2007-2009, a pre-study was carried out on suitable transport vehicles as well as a study of the demands that these vehicles should be able to meet. Five different concepts have been compared and the concept "Self Propelled Modular Transporter" was shown to be the most suitable. This vehicle is built in modules, which means that it is easy to replace parts of the vehicle. The work with the load-carrying system and its interface with the canister transport holder, as well a basic and detailed design will continue throughout the period 2010-2013.

### ***Deposition machine***

The aim of the full-scale tests that are being carried out with completely automated operation is to collect data and evaluate the reliability and availability of the machine and the parts of the system, as well as the service requirements under continuous operation.

During the first four month period of 2010 initial trial run has commenced and product information on the deposition machine has been developed. A few small errors in the software from the supplier Navitec Systems was discovered and will be fixed in the second four month period. A remote connection has been installed and deployed. The remote connection will eventually be used by Navitec Systems to perform distance maintenance of the software of the deposition machine.

### ***Logistics study***

The aim of a more detailed study is to develop the ability, in stages, to be able to simulate the logistics for all the activities in a final repository facility during the operational phase in the long term. A model will be built up within a six month period and the logistics will be developed over a period of several years. One issue which needs to be solved is how to couple autonomic systems with manual systems.

### ***Multi purpose vehicle***

Development is required of a multi purpose vehicle which, among other things, can carry out ramp-transports at Äspö HRL and act as a braking-vehicle for other heavy ramp-vehicles. In addition, the vehicle is needed for handling of material and equipment related to ongoing projects and experiments e.g. KBS-3H, retrieval of canisters in the Prototype Repository, as well as to be used to carry out tests of the function of the whole handling system.

This project have just been initialised and during the first four month period a document of specifications has been drawn up as a base for development of tender inquiry; specification of requirements; contract documents et cetera.

An advertisement was also published on the European homepage of Simap Information on public procurement to reach more companies who may be interested in offering a tender.

### ***Transport system***

A study will be carried out in order to find a solution to the transport of buffer- and backfill material above and below ground. The project is in the start-phase and the transport solutions being studied include a pallet system and transport vehicles.

### ***Drill***

A pre-study will be carried out to construct a new drill that is capable of drilling vertical disposal holes with the required high degree of precision, see Section 4.15.

### ***Production system***

Within this project, a prototype is being developed of a comprehensive automatic system for the management and control of transport and production logistics for the final repository. Completion of the prototype is planned to take about two years.



## 6 Äspö facility

### 6.1 General

The Äspö facility comprises the Äspö Hard Rock Laboratory and the Bentonite Laboratory, the later taken into operation in 2007. The Bentonite Laboratory complements the underground Hard Rock Laboratory and enables full-scale experiments under controlled conditions making it possible to vary experimental conditions and to simulate different environments.

In May 2009 part of the Äspö operation underwent an organisational change as the units *Äspö Hard Rock Laboratory* and *Repository Technology*, both within the Technology department were united. This change was done to focus the remaining development of the repository technology and performing of experiments and tests in a realistic repository environment at Äspö HRL. The new and larger unit inherited the name *Repository Technology*. Äspö HRL is the residence of the unit but the unit includes employees in both Äspö and Stockholm. The main responsibilities of the unit are to:

- Perform technical development commissioned by SKB's programmes for nuclear fuel and for low- and intermediate level waste.
- Develop the KBS-3H concept.
- Perform experiments in the Äspö HRL.
- Secure a safe and cost effective operation of the Äspö HRL.
- Prosecute comprehensive visitor services and information activities in the Oskarshamn area.

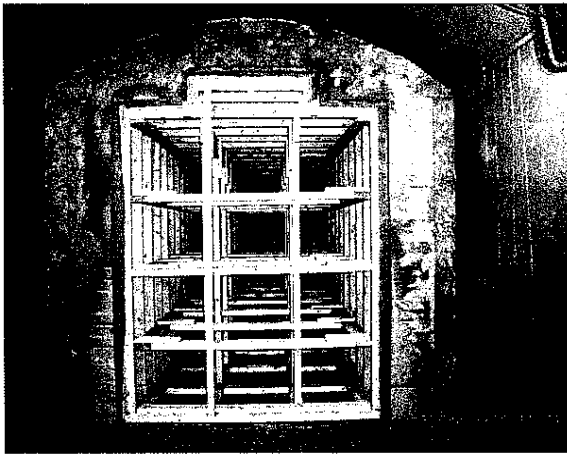
The Repository Technology unit is organised in five operative groups and an administrative staff function:

- *Geotechnical barriers and rock engineering (TDG)*, responsible for the development, testing and demonstration of techniques for installation of buffer, backfill and plugs in deposition tunnels, backfilling of the final repository and plugging of investigation boreholes.
- *Mechanical- and system engineering (TDM)*, responsible for the development, testing and demonstration of equipment, machines and vehicles needed in the final repository.
- *Project and experimental service (TDP)*, responsible for the co-ordination of projects undertaken at the Äspö HRL, providing services (administration, design, installations, measurements, monitoring systems etc.) to the experiments.
- *Public relations and visitor services (TDI)*, responsible for presenting information about SKB and its facilities with main focus on the Äspö HRL.
- *Facility operation (TDD)*, responsible for the operation and maintenance of the Äspö HRL offices, workshops and underground facilities and for development, operation and maintenance of supervision systems.
- *Administration, quality and planning (TDA)*, responsible for planning, reporting, QA, budgeting, environmental co-ordination and administration. The staffing of the Äspö reception and the SKB switchboard are also included in the function.

From May 2010 the Public relations and visitor services group, TDI, organisationally will transfer to the reorganised Communications department within SKB. The group and its personnel will however still be located at Äspö HRL and have a continuously close co-operation with the facility and the daily coordination of underground activities.

Each major research and development task carried out in Äspö HRL is organised as a project led by a Project Manager reporting to the client organisation. Each Project Manager is assisted by an on-site co-ordinator with responsibility for co-ordination and execution of project tasks at the Äspö HRL. The staff at the site office provides technical and administrative service to the projects and maintains the database and expertise on results obtained at the Äspö HRL.

## 6.2 Bentonite Laboratory



*Test set-up for the deposition tunnel in half-scale.*

Before building a final repository, where the operating conditions include deposition of one canister per day, further studies of the behaviour of the buffer and backfill under different installation conditions are required.

SKB has built a Bentonite Laboratory at Äspö, designed for studies of buffer and backfill materials. The laboratory, a hall with dimensions 15×30 m, includes two stations where the emplacement of buffer material at full scale can be tested under different conditions.

The hall is also used for testing of different types of backfill material and the further development of techniques for the backfilling of deposition tunnels.

### **Achievements**

During the first four month of 2010 work has been performed within the final half-scale test (Test 4) done as part of the Baclo project which consisted of filling 5.44 m of the chamber's total 6 m length. This allowed for two, fracture-isolated sections to be constructed within the same assembly (at 2.1 m and 4.2 m distance from the rear of the test chamber, with an additional 1.2 m of backfill installed beyond the location of second wetting band). It also allowed for evaluation of how a series of isolated tunnel sections will interact as water influx to the tunnel progresses. The "fractures" in Test 4 were also supplied with water at 0.0025 l/hr, but wetting was extended to 12 days (288 hrs; 43.2 l total supplied). This ensured isolation of the two sections of tunnel before water was supplied at 0.2 l/min at the rear of the chamber (via two isolated inlet points, each supplying 0.1 l/min).

The final test showed generally similar behaviour to that seen previously where a single isolated pocket of unsaturated backfill pellets existed.

### 6.2.1 Impact of Water Inflow on Backfill



*Migration of the water content in the three layers in test with an inflow rate of 0.1 l/min. Photo of upper surface with meandering water expelled from the steep channel.*

The rock slab test is focusing on the mechanisms that control migration and distribution of water entering pellet fills from inflow spots in the rock. The tests was made on blasted rock slabs for identifying how water is taken up from "dry" and "wet" rock by pellet fills and flows along the rock/pellet contact. The present study comprised of experiments with rock blocks equipped with nozzles for injecting water into contacting pellet fills at constant flow rates. The purpose was to find out if there is a threshold flow rate for "piping" and if channelling at breakthrough takes place along the contact with the confinement as indicated by preceding tests with steel and plexiglass instead of rock.

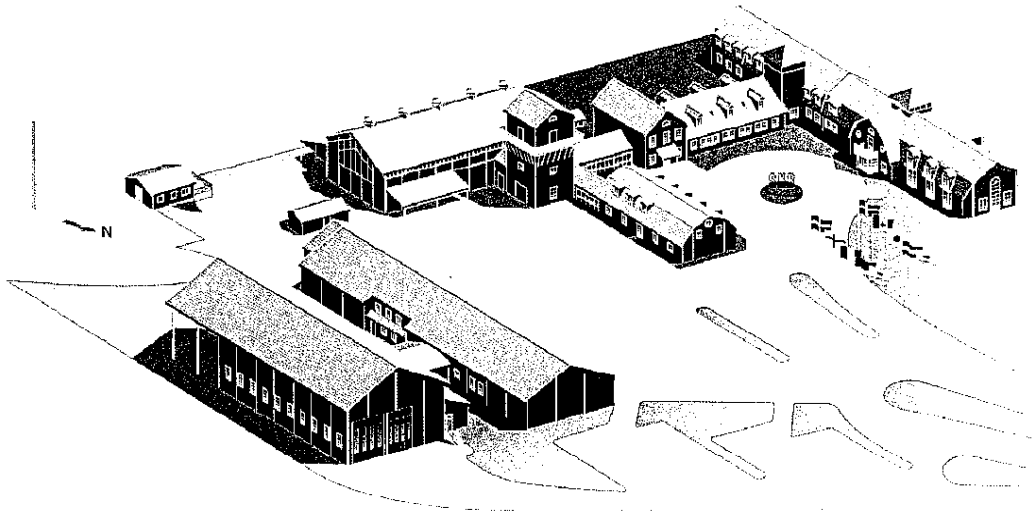
The "half-scale" tests use steel tunnels similar to earlier Baclo experiments but with water inflow from coupled inflow spots simulating water-bearing fractures. The selection of the location of the spots is based on actual fracture mappings of water-bearing fractures in blasted tunnels at the Äspö HRL.

The second part includes a test series in which "wetted pellets" is placed in contact with "dry pellets" for simulating quick water saturation of parts of the tunnel backfill separated by less wet pellet fill into which water flows at a late stage. The major objective of the experiments in these tests is to find out what the critical inflow rate is in order to estimate what the backfilling rate is in meters per day without meeting significant problems.

#### **Achievements**

All tests regarding the impact of water inflow on backfill in the Bentonite Laboratory have been finished. During the period compilation of data from half-scale and stone slab tests have been made. Two final reports are currently being written and will be finished during May. Reviewing of the reports is planned to commence in June and the project will be completed at the end of the second four-month period.

## 6.3 Facility Operation



The main goal for the operation is to provide a safe and environmentally sound facility for everybody working or visiting Äspö.

This includes preventative and remedial maintenance in order to ensure that all systems such as drainage, electrical power, ventilation, alarm and communications have a high degree of availability.

### ***Achievements***

The operation of facility has been stable during the four month period with 100 % availability. The year started with snow and cold weather, which affected the facility and caused high costs for heating and road maintenance due to a large amount of snow.

Rock-maintenance has been re-planned because of a delay to delivery of the contractor's new work-platform (from the factory which has been rebuilt and must be inspected). In one area, at section 2900 m, the walls and roof have been treated with spray-concrete and a number of rock-bolts have been installed, according to the rock-inspection protocol.

The rock-reinforcement which was carried out during the year with spray-concrete has been inspected, in accordance with the rock maintenance programme. The inspection showed that the reinforcements comply with requirements.

Updating of the systematic fire-protection work for all of Äspö laboratory's premises, both above and below ground, has been carried out. A familiarisation with the facility operation has been carried out with the Fire and Rescue Service. The security contract has been terminated, and SKB has signed a new agreement with a security company.

The last stage of the UPS measurement of critical systems, such as the network, security cameras and operational surveillance, has been carried out during the four month period.

New fans have been installed at the sites of new and old experiments and modernisation of the rock-laboratory elevator has begun with the installation of a new safety-computer, according to requirements in the new safety routines.

An independent consultant is carrying out an energy analysis of the facility, and a proposal for energy-saving measures will be completed before the planning of activities for 2011.

## 6.4 Public Relations and Visitor Services



*SKB operates three facilities in the Oskarshamn municipality: Äspö facility, Central interim storage facility for spent nuclear fuel (Clab) and the Canister Laboratory.*

The main goal for the Public Relations and Visitor Services Group is to create public acceptance for SKB, which is done in co-operation with other departments at SKB. The goal will be achieved by presenting information about SKB, the Äspö facility, Clab and the Canister Laboratory.

In addition to the main goal, the information group takes care of and organises visits for an expanding amount of foreign guests every year. The visits from other countries mostly have the nature of technical visits.

The information group has a special booking team at Äspö which books and administrates all visitors. The booking team also is at OKG's service according to agreement.

The team also has the responsibility for the production of SKB's exhibitions.

As from May 2010 the group will be a part of the Department of Communications.

## **Achievements**

SKB facilities have been visited by 5,714 persons during the first four months of 2010. The numbers of visitors to SKB's main facilities are listed in Table 6-1.

There have been a number of VIP-visits during the period, and many of them have been international: CNE, France (Forsmark and Oskarshamn), NWMO, Canada (Oskarshamn), Numo, Japan (Forsmark), Rosatom, Russia, (Oskarshamn), Edram (meeting and visit to SFR in Forsmark), New York Times (Forsmark), Liberala Ungdomsförbundet, national, (Oskarshamn), SSM, Staff and Communication (Oskarshamn) and ÅF Nuclear Trainee to name just a few.

**Table 6-1 - Number of visitors to SKB facilities.**

<b>SKB facility</b>	<b>Number of visitors January-April 2010</b>
Central interim storage facility for spent nuclear fuel	820
Canister Laboratory	497
Åspö HRL	1,853
Final repository for radioactive operational waste (SFR)	2,470

## **7 Environmental research**

### **7.1 General**

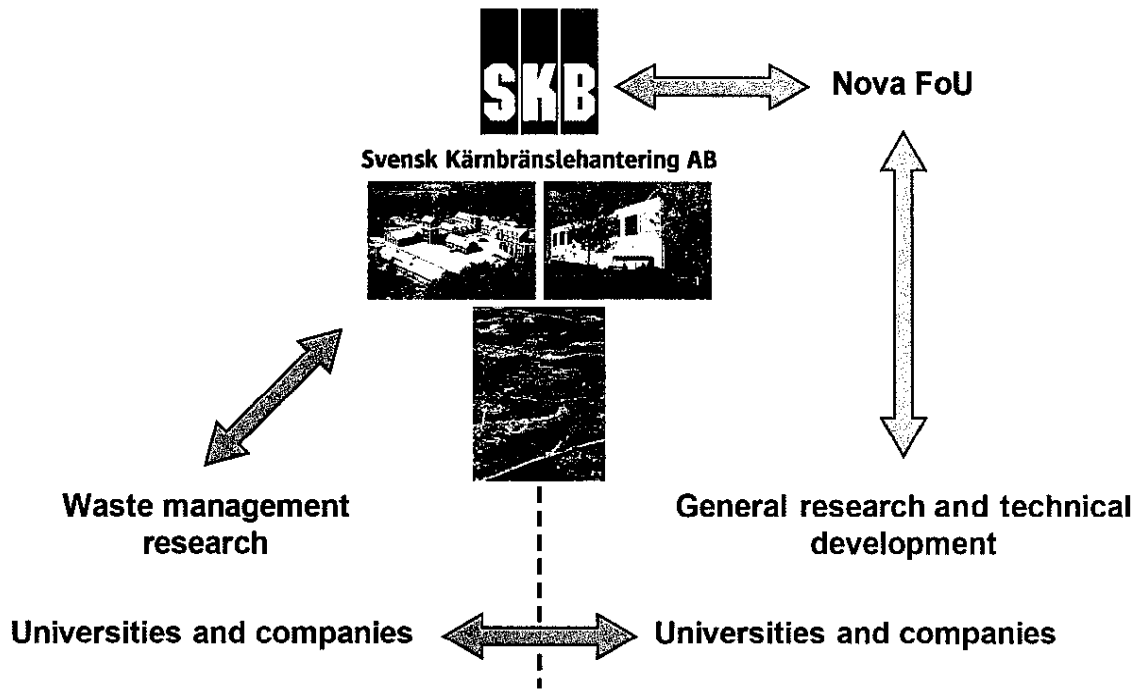
Äspö Environmental Research Foundation was founded in 1996 on the initiative of local and regional interested parties. The aim was to make the underground laboratory at Äspö and its resources available for national and international environmental research. The activities have since 2003 been concentrated to the Äspö Research School. When the activities in the school was concluded as planned in 2008, the remaining and new research activities were transferred within the frame of a new co-operation, Nova Research and Development (Nova FoU).

### **7.2 Nova Research and Development (Nova FoU)**

SKB wants to broaden the use of knowledge and data gathered within the SKB research programme. Nova FoU ([www.novafou.se](http://www.novafou.se)) is the organisation which implements this policy and facilitates external access for research and development projects to SKB facilities in Oskarshamn (Figure7-1). Nova FoU is a joint research and development platform at Nova Centre for University Studies and R&D supported by SKB and the municipality of Oskarshamn.

Nova FoU provides access to the following SKB facilities:

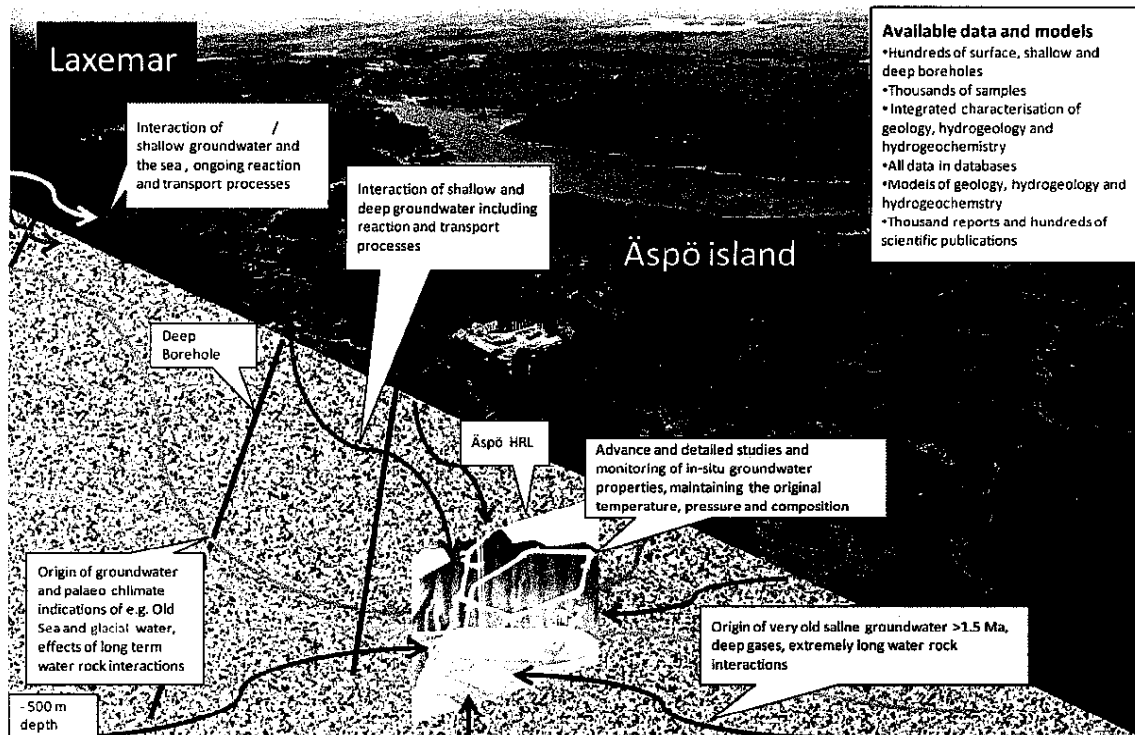
- Äspö Hard Rock Laboratory
- The Bentonite Laboratory at Äspö
- The Canister laboratory in Oskarshamn
- Site Investigation Oskarshamn (Laxemar)



**Figure 7-1** Nova FoU provides access to the SKB facilities and data for universities and companies for general research and technical development. Nuclear waste management research is handled by SKB.

Nova FoU can co-finance the projects by providing access to the SKB facilities, knowledge and data. The costs for these accesses will be calculated by Nova FoU, and will correspond to the amount co-funded by Nova FoU. The aim with the research and development projects through Nova FoU is to create long term spin-offs and business effects beneficial to the region.

Nova FoU supports new and innovative research, for example environmental studies, where the extensive SKB data set from geological, hydrogeological, hydrogeochemical and ecological investigations and modelling can be used (Figure 7-2).



*Figure 7-2 The Äspö and Laxemar areas have been studied in terms of geology, hydrogeology, hydrogeochemistry and ecology. This information can be used for a number of purposes, for example to describe the water cycle and hydrogeochemical processes in 3D.*

The data can be used e.g. for assessing the consequences of natural resource management and pollution risks. The data and models can be used to estimate exposure both at individual and population levels. Development of monitoring and analytical systems can be performed relating to the management of various renewable natural resources in, for instance, agriculture, fisheries, forests and groundwater. Studies which give a better knowledge concerning pollution problems coupled to toxicological and epidemiological issues are possible. Technology, innovations and spin-off effects at pre-market stages are of special interest.

Other possible studies are:

- Groundwater origin, mixing and evolution
- Interaction between large depths, surface and sea
- Model and technology development
- Tunnel and borehole experiments

Ongoing research and development projects, proposed projects and activities and communication activities at Nova FoU are presented in Table 7-1.

**Table 7-1- Nova FoU Projects and activities.**

Ongoing projects	Proposed projects/activities	Communication activities
Linnaeus geochemistry group at Äspö HRL (LNU)	<ul style="list-style-type: none"> <li>▣ Formation of an expert group associated with the harbour remediation project in Oskarshamn</li> <li>▣ Master education for final disposal</li> <li>▣ Water management</li> <li>▣ EU-project</li> <li>▣ Added value discussion</li> <li>▣ Input to the monitoring program for Laxemar and Äspö / Äspö HRL</li> <li>▣ Commercialisation of existing SKB-technique</li> </ul>	<p>Meetings with EU, Vinnova, Formas, Mistra, VR and other corresponding organisations</p> <p>Communication activities together with SKB to invite universities</p> <p>Identification of research teams</p>
Research on microorganisms in groundwater (GU)		
Research on microorganisms in groundwater (University of Göttingen)		
Modelling of hydrological pathways (KTH)		
System development, RFID software Alfagate (NeoSys)		
System development, Fireprotection (NeoSys)		
Energy Efficiency (EoS)		

A short description of the ongoing Nova FoU projects is given below:

- a. **Research and education:** The Linné Geochemistry Group (for details see chapter 7.2.1) at Äspö HRL is a project within the research platform Nova FoU. The group consists of a professor, an associated professor, a post doc and three Ph.D. students. Focus is on research of chemical elements in soil, water, bedrock fractures and biota, and includes detailed studies of how elements are distributed in streams and groundwater at various depths. The research includes field monitoring, laboratory work and modelling. The research projects are funded by Linnaeus University, SKB and KK-Stiftelsen.
- b. **Microbes I:** Research concerning a geogas driven biosphere at Äspö HRL (the project owner is University of Gothenburg).
- c. **Microbes II:** Biomineralisation, biogeochemistry and biodiversity of chemolithotrophic microorganisms in the Äspö tunnel (the project owner is University of Göttingen)
- d. **Coastal modelling:** Hydrogeological pathways and coastal dynamics with integrated transport and altering processes in water from land to sea (the project owner is Royal Institute of Technology, KTH).
- e. **3D localisation system of persons, the Alfagate project:** Development and application of RFID-technology in tunnel environment. Creates an open software structure which is not dependent on hardware and which will be integrated with other Äspö HRL systems (the project owner is NeoSys AB).
- f. **Integrated fire protection, the SAFESITE project:** Fire alarm and safety system associated with the final repository development and application of the RFID-technique (the project owner is NeoSys AB).
- g. **Utilisation of low graded heat, the EoS project:** Research and technological development to utilise excess heat from industry (the project owner is the municipality of Oskarshamn).

The research and education program is the most matured activity within Nova FoU and is therefore described in more detail in the section below.

### 7.2.1 Linné Geochemistry Group



*Four of the members of the Linné Geochemistry Group.*

The Linné Geochemistry Group (previously called "Geochemistry Research Group") is part of the Nova FoU platform. Details on the research activities, the senior researchers and the PhD students are given at <http://www.skb.se/asporesearch>.

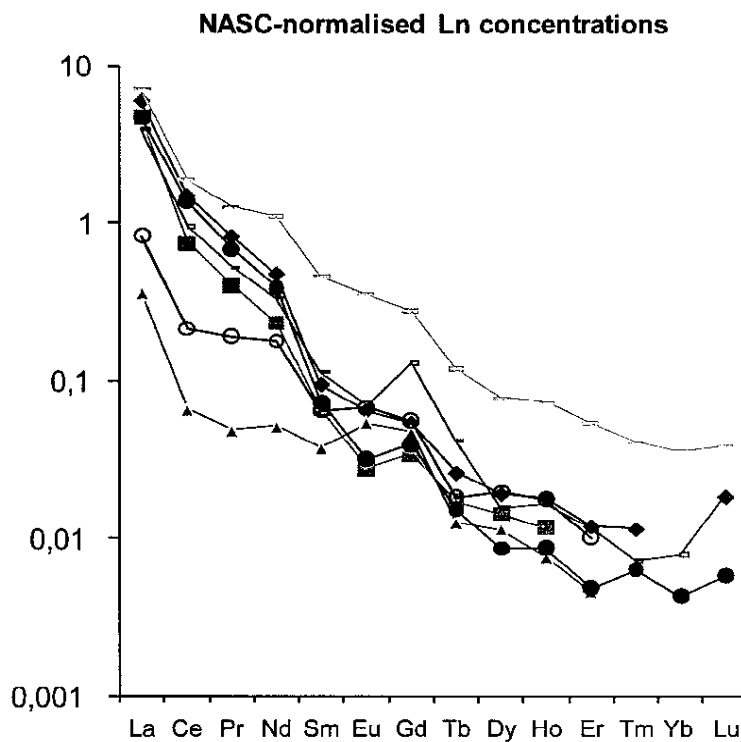
#### **Achievements**

The geochemical studies of waters and fracture minerals collected in Laxemar and at Äspö have continued. The trace element concentrations in low-temperature calcites (Figure 7-3 and Figure 7-4) determined in autumn 2009, have been modelled and interpreted, and will result in two manuscripts. One of the manuscripts will focus on Sr, Mg, Mn and Fe and the other on the lanthanoids. The preparation of the manuscript describing the patterns and pathways of the former metals has started. Also the preparation of two other manuscripts has been initiated. One of them will describe the influence of the relatively young and ironrich Göttemar granitic intrusion on distribution and abundance of fluoride in adjacent surface waters. The other manuscript will focus on results of M3 modelling of Äspö hydrochemical data in order to characterise water mixing, water-rock interactions and variations over time in various ion concentrations in the Äspö bedrock.

Two PhD positions were advertised, and two persons were selected from the around 30 applicants. The ones selected were Olga Maskenskaya from Russia and Changxun Yu from China. They have both been accepted as PhD students by the Faculty at the Linnaeus University, and they are currently waiting for acceptance of visa applications. Olga will focus her studies on trace elements in both low and high temperature fracture-filling minerals, while Changxun will carry out geochemical studies of both solids and aqueous phases.



**Figure 7-3** SEM-pictures of calcite in borehole KLX10 at the depth of 698 m. Trace-element concentrations in the calcites have been studied in order to better describe the environment in which the calcites were formed and to determine what capacity the calcites have to scavenge metals from the surrounding solution.



**Figure 7-4** Strong enrichment of light lanthanoids in low-temperature calcites collected from fracture walls in the bedrock at Laxemar. NASC represents the Ln-concentrations.

## 8 International co-operation

### 8.1 General

Nine organisations from eight countries will in addition to SKB participate in the co-operation at Äspö HRL during 2010, see Table 8-1. Six of them; Andra, BMWi, CRIEPI, JAEA, NWMO and Posiva together with SKB form the Äspö International Joint Committee (IJC), which is responsible for the coordination of the experimental work arising from the international participation. Numo (Nuclear Waste Management Organisation of Japan) had a representative observer at the IJC-meeting in May, 2009.

**Table 8-1 Participation in the Äspö HRL during 2010.**

Projects in the Äspö HRL during 2010	Andra	BMWi	CRIEPI	JAEA	NWMO	Posiva	Kaeri	Nagra	Rawra
<b>Natural barriers</b>									
Long Term Sorption Diffusion Experiment					X				
Colloid Transport Project		X			X				
Microbe Project		X							
Task Force on Modelling of Groundwater Flow and Transport of Solutes	X		X	X	X	X	X		
<b>Engineered barriers</b>									
Prototype Repository		X							
Alternative Buffer Materials	X	X				X		X	X
Long Term Test of Buffer Materials	X	X				X		X	
Temperature Buffer Test	X	X							
KBS-3 Method with Horizontal Emplacement						X			
Large Scale Gas Injection Test	X	X			X	X			
Task Force on Engineered Barrier Systems		X	X		X	X		X	X
<b>Participating organisations :</b>									
Agence nationale pour la gestion des déchets radioactifs, Andra, France									
Bundesministerium für Wirtschaft und Technologie, BMWi, Germany									
Central Research Institute of the Electronic Power Industry, CRIEPI, Japan									
Japan Atomic Energy Agency, JAEA, Japan									
Nuclear Waste Management Organisation, NWMO, Canada									
Posiva Oy, Finland									
Korea Atomic Energy Research Institute, Kaeri, Korea									
Nationale Genossenschaft für die Lagerung Radioaktiver Abfälle, Nagra, Switzerland									
Radioactive Waste Repository Authority, Rawra, Czech Republic									

Several of the participating organisations take part in the two Äspö Task Forces on: (a) Modelling of Groundwater Flow and Transport of Solutes, which is a forum for co-operation in the area of conceptual and numerical modelling of groundwater flow and solute transport in fractured rock and (b) THMC modelling of Engineered Barrier Systems, which is a forum for code development on THMC processes taking place in a bentonite buffer and gas migration through a buffer.

SKB also takes part in work within the IAEA framework. Äspö HRL is part of the IAEA Network of Centres of Excellence for training in and demonstration of waste disposal technologies in underground research facilities.

## **9 Documentation**

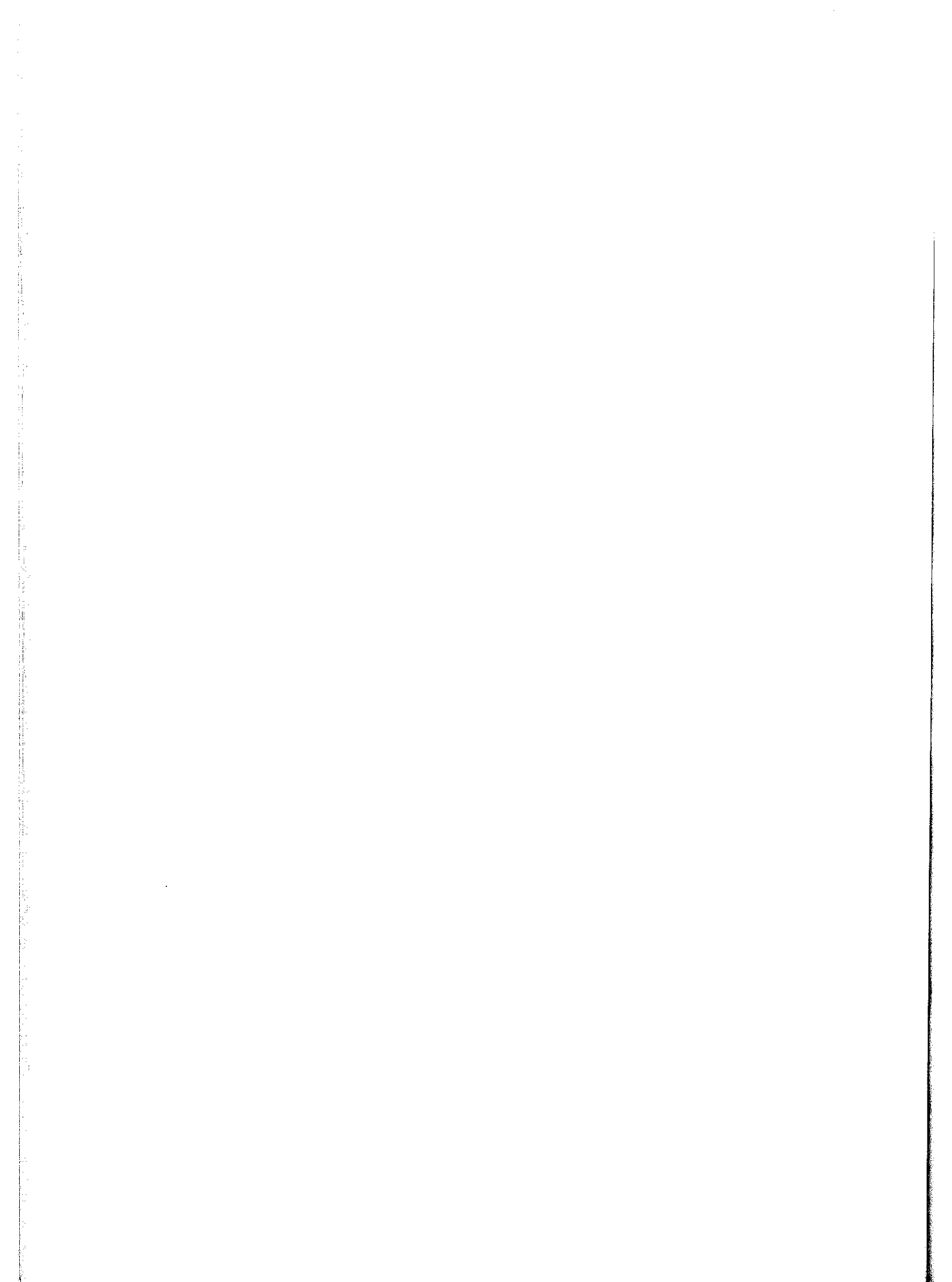
During the period January - April 2010, the following reports have been published and distributed.

### **9.1 Äspö International Progress Reports**

**Gustafsson J, Gustafsson G, 2010.** BIPS logging in borehole KAS09. SKB IPR-10-02, Svensk Kärnbränslehantering AB.

### **9.2 Technical Documents and International Technical Documents**

Two Technical Documents have been published during the period January – April 2010.



## 10 References

- Andersson C and Johansson Å, 2002.** Boring of full scale deposition holes at the Äspö Hard Rock Laboratory. Operational experiences including boring performance and a work time analysis. SKB TR-02-26, Svensk Kärnbränslehantering AB.
- André M, Malmström M E, Neretnieks I, 2009.** Specific surface area measurements on intact drill cores and evaluation of extrapolation methods for rock matrix surfaces. *Journal of Contaminant Hydrology*, 110(1):1-8. doi:10.1016/j.jconhyd.2009.05.003.
- Autio J, 1997.** Characterization of the excavation disturbance caused by boring of the experimental full scale deposition holes in the Research Tunnel at Olkiluoto. SKB TR 97-24, Svensk Kärnbränslehantering AB.
- Berglund J, Curtis P, Eliasson T, Olsson T, Starzec P, Tullborg E-L, 2003.** Update of the geological model 2002. SKB IPR-03-34, Svensk Kärnbränslehantering AB.
- Cvetkovic V, 2010.** Significance of fracture rim zone heterogeneity for tracer transport in crystalline rock, *Water Resources Research*, doi: 10.1029/2009WR007755.
- Cvetkovic V, in press.** Diffusion-controlled tracer retention in crystalline rock on a field scale. *Geophysical Research Letters (GRL)*, in press.
- Cvetkovic V, Frampton A, 2010.** Transport and retention from single to multiple fractures in crystalline rock at Äspo (Sweden): 2. Fracture network simulations and generic retention model, *Water Resources Research*., doi:10.1029/2009WR008030.
- Cvetkovic V, Cheng H, Byegard J, Winberg A, Tullborg E-L and Widestrand H, 2010.** Transport and retention from single to multiple fractures in crystalline rock at Äspo (Sweden): 1. Evaluation of tracer test results and sensitivity analysis, *Water Resources Research*., doi:10.1029/2009WR008013.
- Cvetkovic V. et al., in prep.** Would crystalline rock effectively contain radionuclides released from a high-level nuclear waste repository? (Tentative title). Paper in preparation.
- Dubois I E, Holgersson S, Allard S, Malmström M E, 2009.** Dependency of BET surface area on particle size for some granitic minerals (submitted).
- Dubois I E, Holgersson S, Allard S, Malmström M E, 2010.** Correlation between particle size and surface area for chlorite and K-feldspar. 13th Water Rock Interaction (WRI-13), Guanajuato, Mexico, Aug 16-20, 2010 (Tentatively accepted).
- Goudarzi R, Johannesson L-E, 2009.** Äspö Hard Rock Laboratory. Prototype Repository. Sensors data report (Period 010917-091201). Report No: 22. SKB IPR-10-05, Svensk Kärnbränslehantering AB.
- Hakami H, 2003.** Update of the rock mechanical model 2002. SKB IPR-03-37, Svensk Kärnbränslehantering AB.

**Laaksoharju M, Gurban I, 2003.** Update of the hydrogeochemical model 2002. SKB IPR-03-36, Svensk Kärnbränslehantering AB

**Malmström M E, Byegård J, Höglund S, Docampo Cabaleiro E, 2010.** Process-based modelling of sorption as a possible tool within performance assessment and site characterisation modelling – a pilot case exercise. SKB report (draft report).

**Smart N R and Rance A P, 2009.** Miniature Canister Corrosion Experiment – Results of Operations to May 2008, SERCO/TAS/E.001607.01, Issue 1, and SKB report TR-09-20, 2009.

**Smart N R, Rance A P, Reddy B, 2009.** Miniature Canister (MiniCan) Corrosion Experiment Progress Report 1 for 2008-9, SERCO/TAS/E.003110.01, Issue 1, 2009.

**Smart N R, Rance A P, Reddy B, 2010.** Miniature Canister (MiniCan) Corrosion Experiment Progress Report 2 for 2008-9, SERCO/TAS/E.003110.02, Issue 1, 2010.

**Vidstrand P, 2003.** Update of the hydrogeological model 2002. SKB IPR-03-35, Svensk Kärnbränslehantering AB.